

Classic

BATHROOM COLLECTION

Classic

COLLECTION

Una collezione di arredi di notevole importanza e varietà.

Questa raccolta comprende mobili da bagno di stile classico, l'ispirazione è quella della prestigiosa tradizione artigianale italiana. Oltre alle classiche finiture e laccature, proponiamo molte tecniche artigianali e artistiche quali la foglia, l'intarsio, l'intaglio, l'imbottitura capitonnè e persino la pittura. Il lavoro manuale riveste un ruolo fondamentale, chi sceglie questi arredi deve saper apprezzare le caratteristiche artigianali del prodotto, questi mobili sono uno diverso dall'altro dunque esulano dal concetto di produzione industriale. Gli spunti creativi sono molti: da contesti classici sobri ed eleganti, a proposte sontuose e "principesche", sino al design accattivante e creativo della linea decò. Tutto questo in un grande ricco catalogo che speriamo possa darvi delle "emozioni" o comunque delle idee, per rendere meraviglioso il vostro bagno.

A vast collection of bathroom furniture, which includes classic furniture, inspired by the prestigious Italian handicraft traditions. In addition to the classic finishes and lacquering, we offer many craft and artistic techniques such as gold leaf and silver, inlay, carving, quilted padding and even painting. As manual labour plays an important role, those who choose these fittings will also appreciate the artisan characteristics of the product as this type of furniture has unique design as it falls outside the concept of industrial production. Creative ideas are many: from simple and elegant classical themes, to sumptuous and "princely" proposals as well as the attractive creative Art Deco lines. All this can be found in a large and rich catalogue which we hope to give you the emotions and right ideas to make your bathroom beautiful.



LEGNOBAGNO®
IL BAGNO CHE ARREDA

“La classicità riflette
l’anima dei tempi
che attraversa”

“Classicism reflects the spirit of the times”

Classic

COLLECTION

RETRÒ
{COMPONIBILE}
pag. 04



RETRÒ **PAG.06**
RETRÒ PROVENZALE **PAG.48**

STYLE
{MONOBLOCCHI}
pag. 56



GLAM **PAG.56**
VINTAGE **PAG.66**
VANITY **PAG.84**
VANITY CAPITONNÈ **PAG.108**
VANITY DUETTO **PAG.116**
VANITY INTAGLIATO **PAG.128**
NARCISO **PAG.134**
NARCISO DECORATO **PAG.150**
VOGUE **PAG.156**
NOVECENTO **PAG.176**

DECÒ
{MONOBLOCCHI}
pag. 194



DECÒ CLASSIC **PAG.194**
DECÒ LINEARE **PAG.226**

RETRÒ. IL COUNTRY CHIC

L'INTRAMONTABILE PASSIONE PER IL LEGNO SI ESPRIME NELLA RINNOVATA COLLEZIONE RETRÒ, una serie di mobili da bagno classici, ma al contempo attuali, che creano ambienti tradizionali dal gusto "Country Chic". Le molteplici tonalità di finiture legno, i colori decapé, i laccati a poro aperto, donano a questa collezione infinite possibilità di abbinamenti. La tradizionale anta con il telaio in massello e le particolari fiancate con il piedino sagomato, caratterizzano fortemente questo modello, che esprime tutta la nostra passione per il mobile classico e senza tempo.



RETRÒ. THE COUNTRY CHIC

The timeless passion for wood is expressed in the renewed Retrò collection, a series of classic yet contemporary bathroom furniture, which create traditional environments with a "Country Chic" taste. The many shades of wood finishes, the decapé colors, the open pore lacquers give this collection endless possibilities for combinations. The traditional door with the solid wood frame and the particular sides with the shaped foot, strongly characterize this model, which expresses all our passion for classic and timeless furniture.





RETRÒ R211





RETRÒ R211

Colore composizione: Bianco a poro aperto

Specchiera e illuminazione: Specchio con cornice legno "Large", lampade "Goccia" cromo con vetro soffiato

Top lavabo: Gres porcellanato con vasca lavabo integrata, colore Grigio Amani Lucido

Mobile di complemento: Vetrina 2 ante 2 cassetti, colore Bianco a poro aperto



Composition color: White open pore

Mirror and light: mirror with wood frame "Large", chrome lamp "Goccia" with blown glass

Washbasin top: porcelain stoneware with integrated basin, Gloss Amani Grey color

Complementary furniture: Showcase 2 doors 2 drawers, White open pore color

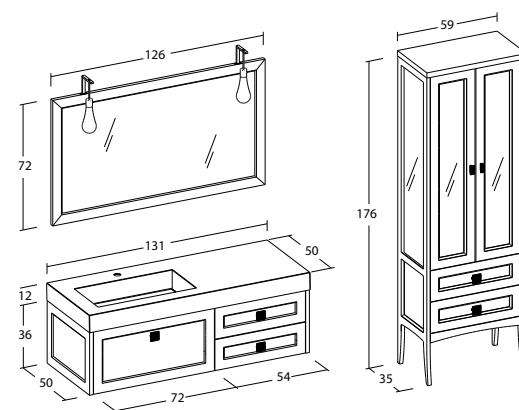



RETRÒ R212





RETRÒ R212

Colore Composizione: Bianco a poro aperto

Specchiera e illuminazione: Specchio con cornice legno "Fashion", lampada "Goccia" cromo con vetro soffiato

Top lavabo: Marmo Bianco Carrara spessore 3 cm, lavabo ad appoggio in ceramica "Nice 50"

Mobile di complemento: Vetrina 2 ante 2 cassetti, colore Bianco a poro aperto



Composition color: White open pore

Mirror and light: mirror with wood frame "Fashion", chrome lamp "Goccia" with blown glass

Washbasin top: Carrara White Marble 3 cm thick, countertop ceramic washbasin "Nice 50"

Complementary furniture: Showcase 2 doors 2 drawers, White open pore color

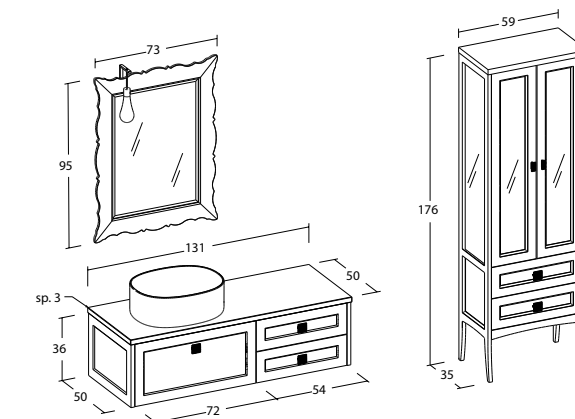

RETRÒ R213

Colore Composizione: Bianco a poro aperto

Specchiera e illuminazione: Specchio con cornice legno "Fashion", lampada "Goccia" cromo con vetro soffiato

Top lavabo: Marmo Bianco Carrara spessore 3 cm, lavabo ad appoggio in ceramica "Nice 50"

Mobile di complemento: Vetrina 2 ante 2 cassetti, colore Bianco a poro aperto



Composition color: White open pore

Mirror and light: mirror with wood frame "Fashion", chrome lamp "Goccia" with blown glass

Washbasin top: Carrara White Marble 3 cm thick, countertop ceramic washbasin "Nice 50"

Complementary furniture: Showcase 2 doors 2 drawers, White open pore color

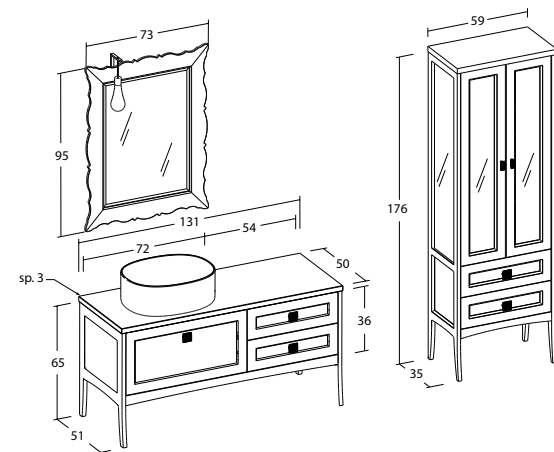

Versione a terra con piedi.
Floor version with support.





RETRÒ R214





RETRÒ R214

Colore Composizione: Decapè Verde Acqua

Specchiera e illuminazione: Specchio con cornice legno "Retrò", lampade "Melody" cromo

Top lavabo: Marmo White Iceberg, lavabo sottopiano in ceramica "Retrò"

Mobile di complemento: Vetrina 1 ante 2 cassetti, colore Decapè Verde Acqua



Composition color: Green Water Decapè

Mirror and light: Mirror with wood frame "Retrò", chrome lamps "Melody"

Washbasin top: White Iceberg Marble, recessed ceramic washbasin "Retrò"

Complementary furniture: Showcase 1 door 2 drawers, Green Water Decapè color

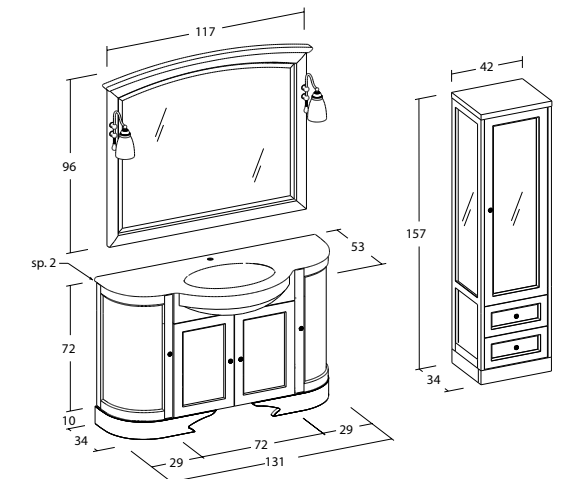

**RETRÒ
R215**
❧





RETRÒ R215

Colore Composizione: Decapè Avorio
Specchiera e illuminazione: Specchio con cornice legno "Retrò", lampade "Melody" cromo
Top lavabo: Marmo Tecnico Botticino, lavabo sottopiano in ceramica "Idea"
Mobili di complemento: Vetrina 1 ante
 2 cassetti, colore Decapè Avorio



Composition color: Ivory Decapè
Mirror and light: Mirror with wood frame "Retrò", chrome lamps "Melody"
Washbasin top: Technical Botticino Marble, recessed ceramic washbasin "Idea"
Complementary furniture: Showcase
 1 door 2 drawers, Ivory Decapè color

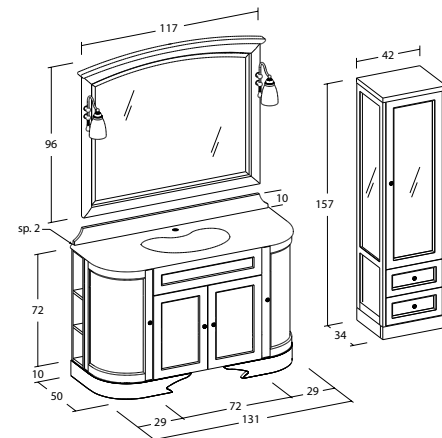

RETRÒ
R216
∞



RETRÒ R216

Colore Composizione: Rovere Sbiancato Patinato
Specchiera e illuminazione: Specchio con cornice legno "Albatros", lampada "Dafne" cromo
Top lavabo: Marmo White Iceberg, lavabo sottopiano in ceramica "Retrò"
Mobile di complemento: Sgabello contenitore, colore Rovere Sbiancato patinato



Composition color: White Oak Coated
Mirror and light: Mirror with wood frame "Albatros", chrome lamp "Dafne"
Washbasin top: White Iceberg Marble, recessed ceramic washbasin "Retrò"
Complementary furniture: footstool with storage, White Oak Coated color

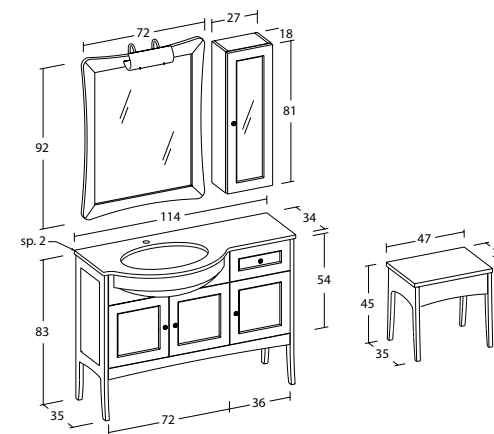

RETRÒ R217



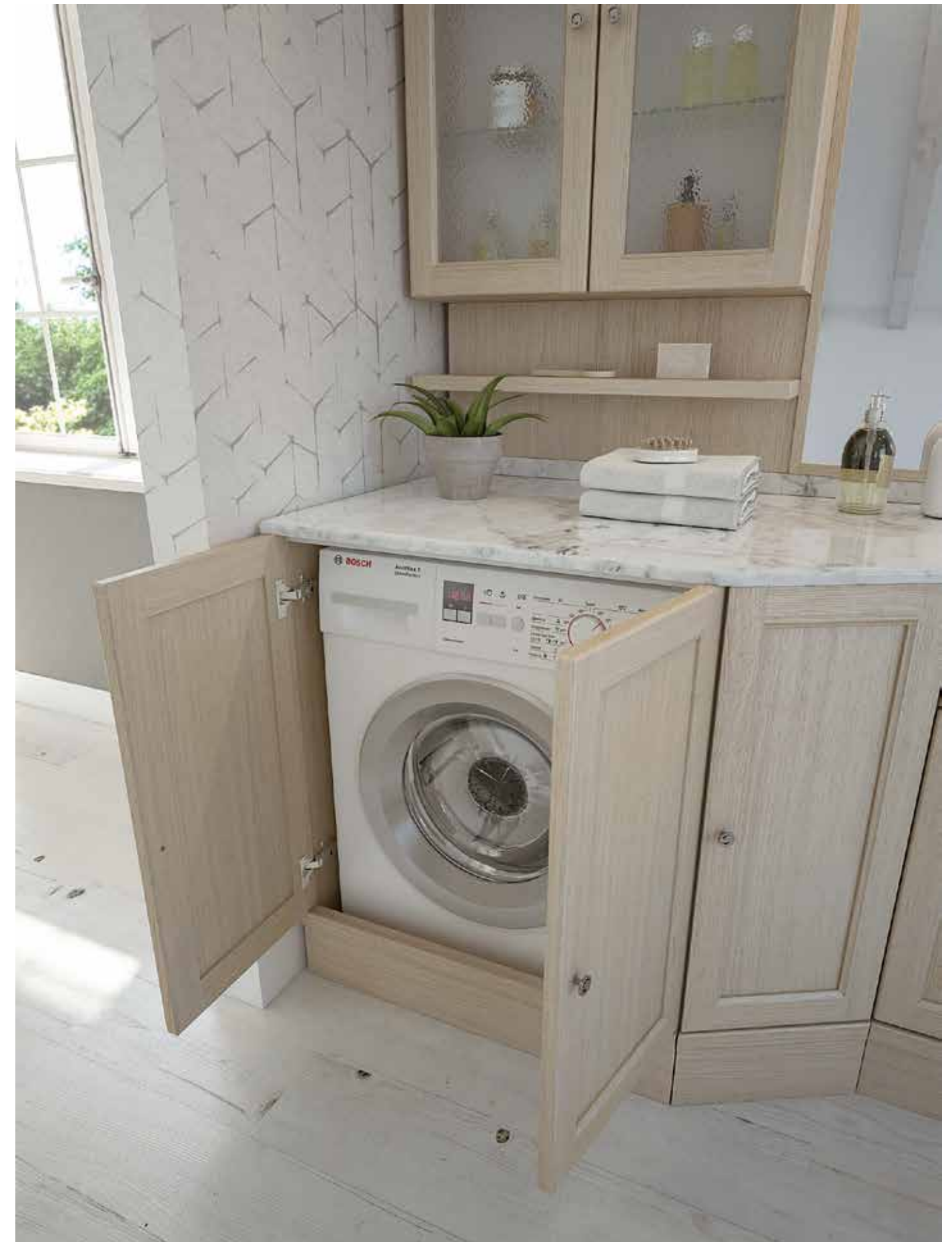

RETRÒ R217

Colore Composizione: Rovere Sbiancato patinato
Specchiera e illuminazione: Specchio con cornice legno "Slim", con pensili e pensilina con faretti
Top lavabo: Marmo Bianco Carrara, lavabo sottopiano in ceramica "Enjoy"



Composition color: White Oak Coated
Mirror and light: Mirror with wood frame "Slim", with wall units and platform room with spotlights
Washbasin top: Carrara White Marble, recessed ceramic washbasin "Enjoy"

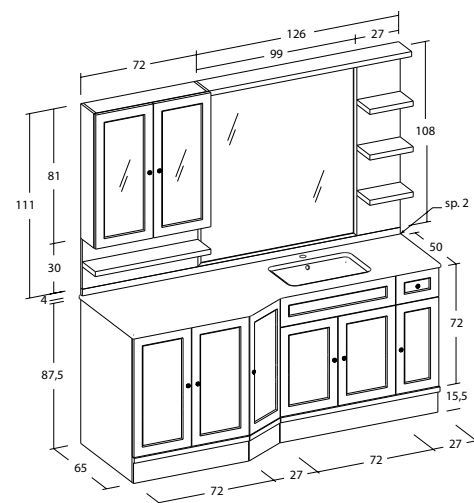



**RETRÒ
RC01**
∞



RETRÒ RCO1

Colore Composizione: Decapè Azzurro Cielo
Specchiera e illuminazione: Specchio con cornice legno "Retrò", lampade "Melody" cromo
Top lavabo: Marmo Bianco Carrara, lavabo sottopiano in ceramica "Retrò"
Mobile di complemento: Vetrina 1 ante 2 cassetti, colore Decapè Azzurro Cielo



Composition color: Sky Blue Decapè
Mirror and light: Mirror with wood frame "Retrò", chrome lamps "Melody"
Washbasin top: Carrara White Marble, recessed ceramic washbasin "Retrò"
Complementary furniture: Showcase 1 door 2 drawers, Sky Blue Decapè color

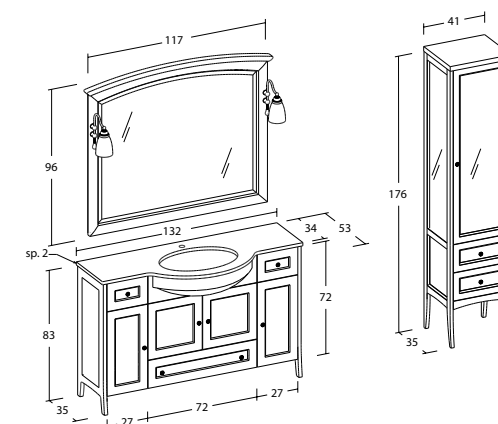



RETRÒ
R207
~

RETRÒ R207

Colore Composizione: Rovere Sbiancato Patinato
Specchiera e illuminazione: Specchio con cornice legno "Large", pensilina con faretti
Top lavabo: Marmo White Iceberg, lavabo sottopiano in ceramica "Luna"



Composition color: White Oak Coated
Mirror and light: Mirror with wood frame "Large", platform room with spotlights
Washbasin top: White Iceberg Marble, recessed ceramic washbasin "Luna"

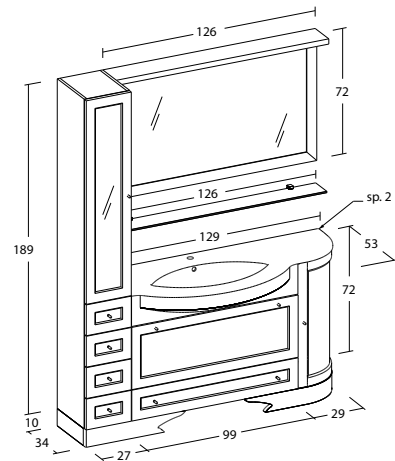

**RETRÒ
R208**
❧





RETRÒ R208

Colore Composizione: Rovere Noce

Specchiera e illuminazione: Specchio con cornice legno "Slim", con pensili e pensilina con faretti

Top lavabo: Marmo Tecnico Bianco Polare, lavabo sottopiano in ceramica "Retrò"



Composition color: Walnut Oak

Mirror and light: Mirror with wood frame "Slim", with wall units and platform room with spotlights

Washbasin top: Technical Polar White Marble, recessed ceramic washbasin "Retrò"

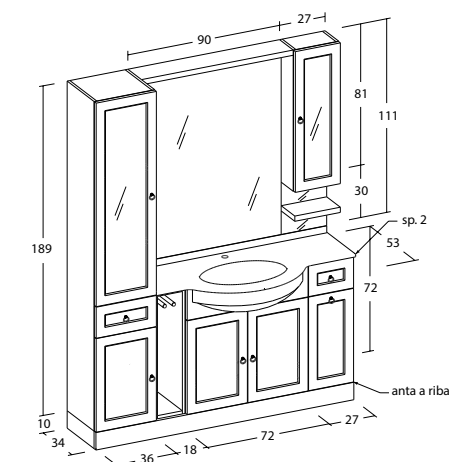

RETRÒ
R210
∞



RETRÒ R210

Colore Composizione: Decapè Avorio
Specchiera e illuminazione: Specchio con cornice legno "Retrò", lampade "Melody" cromo
Top lavabo: Marmo Tecnico Botticino 3 cm, lavabo Semincasso standard in ceramica



Composition color: Ivory Decapè
Mirror and light: Mirror with wood frame "Retrò", chrome lamps "Melody"
Washbasin top: Technical Botticino Marble 3 cm, semi-recessed standard ceramic washbasin

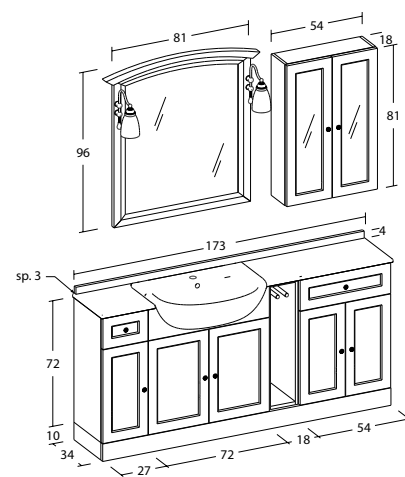



RETRÒ 01
PROVENZALE

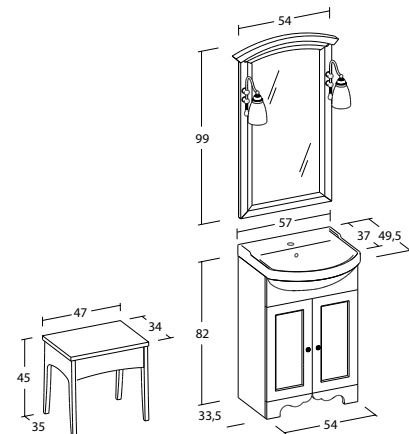

Colore Composizione: Decapè Avorio
Specchiera e illuminazione: Specchio con cornice legno "Retrò", lampade "Melody" cromo
Top lavabo: Consolle in ceramica non a filo cm 57
Mobile di complemento: Sgabello contenitore, colore Decapè Avorio



Composition color: Ivory Decapè
Mirror and light: Mirror with wood frame "Retrò", chrome lamps "Melody"
Washbasin top: non-flush ceramic console cm 57
Complementary furniture: footstool with storage, Ivory Decapè color



RETRÒ 02
PROVENZALE

Colore Composizione: Rovere Noce
Specchio con cornice legno "Slim", con pensile Provenzale e pensilina con faretto
Top lavabo: Consolle in ceramica non a filo cm 74
Mobile di complemento: Vetrina 1 ante 2 cassetti, colore Rovere Noce



Composition color: Walnut Oak
Mirror with wood frame "Slim", with wall unit Provenzale and platform room with spotlights
Washbasin top: non-flush ceramic console cm 74
Complementary furniture: Showcase 1 door 2 drawers, Walnut Oak color

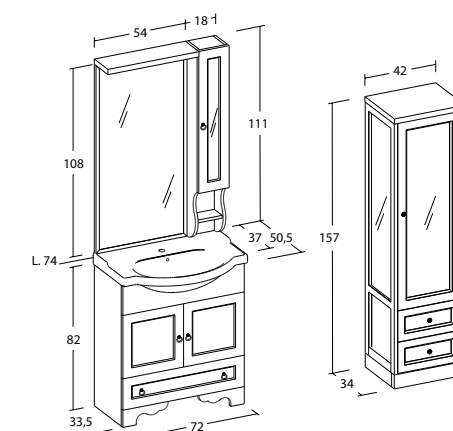



RETRÒ 03 PROVENZALE

Colore composizione: Decapè Verde Acqua
Specchiera e illuminazione: Specchio con cornice legno "Retrò", lampade "Melody" cromo
Top lavabo: Consolle in ceramica non a filo cm 86
Mobile di complemento: Vetrina 1 ante 2 cassetti, colore Decapè Verde Acqua



Composition color: Green Water Decapè
Mirror and light: Mirror with wood frame "Retrò", chrome lamps "Melody"
Washbasin top: non-flush ceramic console cm 86
Complementary furniture: Showcase 1 door 2 drawers, Green Water Decapè color

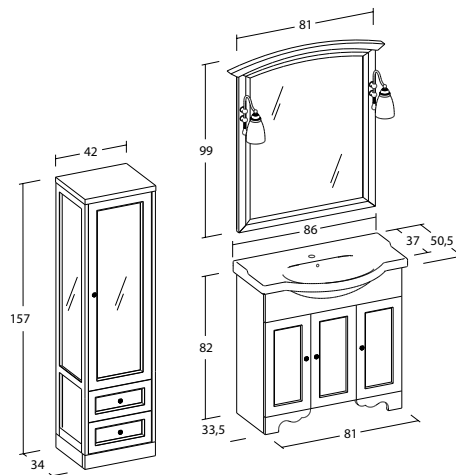

RETRÒ 04 PROVENZALE

Colore Composizione: Rovere Sbiancato Patinato
Specchio con cornice legno "Slim", con pensile
Provenzale e pensilina con faretti

Top lavabo: Consolle in ceramica a filo colonna cm 101



Composition color: White Oak Coated
Mirror with wood frame "Slim", with wall unit Provenzale
and platform room with spotlights

Washbasin top: ceramic column console cm 101

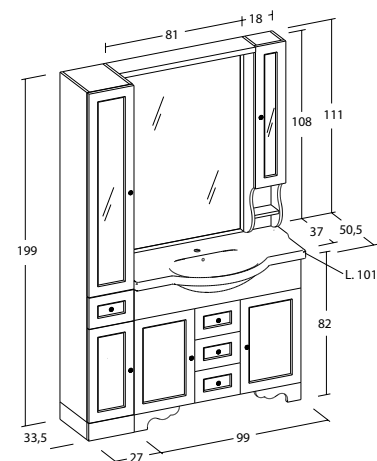

GLAM. NEL SEGNO DELL'ELEGANZA

IL GLAM È UNA CONSOLLE DI ELEGANZA STRAORDINARIA. LE LINEE SONO SINUOSE E SOBRIE, IL DESIGN È MODERNO MA EVOCA LE FORME CLASSICHE IN MODO "GARBATO" ED ORIGINALE. È DISPONIBILE NELLA VERSIONE CON TRE CASSETTI (IN QUESTO CASO LACCATI, FOGLIA O ALTRE FINITURE). TUTTE LE FINITURE SONO POSSIBILI: LACCATI LUCIDI E OPACHI, ANTICATI E SPIGOLATI. MERAVIGLIOSE LE MANIGLIE, IN FINITURA ORO E CROMO CON Swarovski elements.



GLAM. IN THE NAME OF ELEGANCE

Glam is a console table of extraordinary elegance. The lines are curvy and simple, the design is modern but evokes classic shapes in a gentle and original way. It is available with three drawers (in this case lacquered, with leaf or other finishes). All finishes are possible: glossy and matt, antiqued and rub-through lacquers. The handles are wonderful with chrome and gold finish and Swarovski elements.





GLAM 01

La sorpresa di vedere due volti che si incontrano, colori giovani e freschi in felice connubio. Una proposta esuberante e di grande carattere.



The surprise of seeing two faces that meet, young and fresh colours in a perfect combination. An exuberant offer of great character.



GLAM 01

Colore composizione: Struttura bianco lucido e frontali caffè latte lucido.

Materiali: Legno multistrato e gambe in legno massello.

Top lavabo: Piano in marmo bianco Carrara e lavabo sottopiano universale.

I particolari: Maniglie e lampade con Swarovski elements.



Color composition: Glossy white frame and glossy coffee milk front.

Materials: Multilayer wood and solid wood legs.

Top: White Carrara marble top and standard wash-basin undertop.

Detail: Handles and lamps with Swarovski elements.

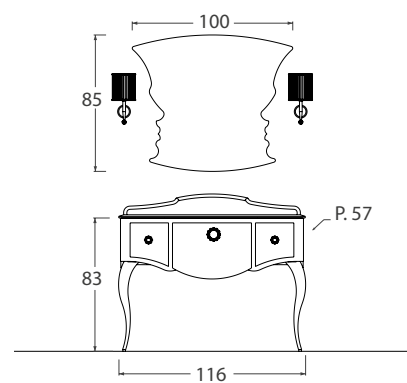

Maniglia con Swarovski elements (a richiesta)
Handle with Swarovski elements (on request)



Maniglia cromo/oro (di serie)
Chrome/gold handle (standard)



GLAM 03

Eleganza e raffinatezza che possono emozionare. Il nero e la foglia oro sono un classico, mai scontato e di effetto garantito. Notare la ricchezza dei particolari, anche nelle lampade e nelle preziose maniglie.



Elegance and refinement that can excite. Black and gold leaf is a classic, never commonplace and with guaranteed effect. Note the richness of detail, even in the lamps and precious handles.





PER IL MODELLO GLAM SONO DISPONIBILI 2 TIPI DI MANIGLIE.
THERE ARE 2 TYPES OF HANDLES FOR THE GLAM MODEL.



Maniglia con Swarovski elements (a richiesta)
Handle with Swarovski elements (on request)



Maniglia cromo/oro (di serie)
Chrome/gold handle (standard)

GLAM 03

Colore composizione: Struttura nero lucido e cassetti foglia oro.
Materiali: Legno multistrato e gambe in legno massello.
Top lavabo: Cristallo integrale rivestito in foglia oro.
I particolari: Maniglie e lampade con Swarovski elements.



Color composition: Glossy black frame and gold leaf drawers.
Materials: Multilayer wood and solid wood legs.
Top: Integrated glass covered with gold leaf.
Detail: Handles and lamps with Swarovski elements.

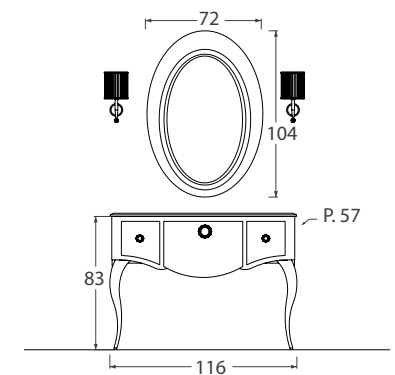

VINTAGE. MAESTOSITÀ, CLASSE E FUNZIONALITÀ

IL VINTAGE È UN MOBILE DI STRAORDINARIA IMPORTANZA. IL SUO CORPO E LA SUA STRUTTURA SONO ESTREMAMENTE CONSISTENTI MA AL CONTEMPO LE FORME SONO EQUILIBRATE E SINUOSE. È UN MOBILE CHE SI DISTINGUE CON UN DISEGNO ORIGINALE. LA BELLEZZA STILISTICA SI ACCOMPAGNA ANCHE ALLA FUNZIONALITÀ, IL VINTAGE DISPONE INFATTI DI TRE CAPIENTI CASSETTONI. È DISPONIBILE IN UNICA VERSIONE CON TRE CASSETTI IN TUTTE LE FINITURE POSSIBILI: NOCE, LACCATI LUCIDI E OPACHI, ANTICATI, SPIGOLATI E FOGLIA. DI GRANDE CLASSE ED IMPATTO LA VERSIONE CON IMBOTTITURA CAPITONNÉ, A NOSTRO PARERE LA FINITURA IN CUI TROVA LA SUA MASSIMA ESPRESSIONE.



VINTAGE. MAJESTY, CLASS AND FUNCTIONALITY

Vintage is a piece of extraordinary magnificence. Its body and frame are very compact but feature balanced and sinuous shapes at the same time. It is a piece of furniture that stands out because of its original design. The stylistic beauty is also accompanied by functionality. Vintage in fact features three spacious drawers. It is available in only one version with three drawers and all the finishing options: walnut, glossy and matte, antique, rub-through and leaf lacquers. The version with quilted padding has great impact and class. In our opinion this finish interprets it the best possible way.



VINTAGE 01

Un mobile che è emblema e fonte di ispirazione di tutto il progetto. La ricchezza di questo mobile è ricercata in ogni particolare, il bianco e il nero si alternano con eleganza in ogni dettaglio.



A piece of furniture that is an emblem and a source of inspiration for the entire project. The richness of this piece of furniture is found in every detail, the white and black alternate with elegance in every detail.





VINTAGE 01

Colore composizione: Struttura nero lucido e cassetti con imbottitura capitonnè in pelle bianca.
Materiali: Legno multistrato e gambe in legno massello.
Top lavabo: Piano in marmo Nero Marquina e lavabo sottopiano universale.
Apertura cassetti: Push-pull / Spingi apri.



Color composition: Glossy black frame with white leather quilted padding.
Materials: Multilayer wood and solid wood legs.
Top: Black Marquina marble top and standard wash-basin undertop.
Drawer opening: Push-pull / Push open.

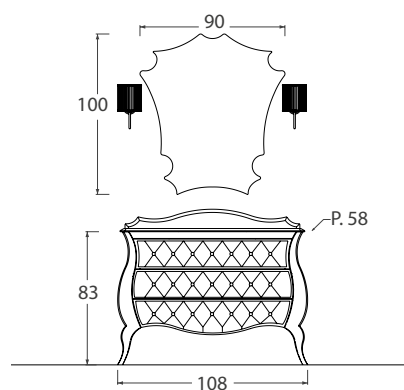

VINTAGE 02

Grande effetto anche in una delle finiture più tradizionale: il noce. In ottimale abbinamento con un marmo davvero esclusivo: il New Emperador.



It creates a great effect even with a more traditional finish: walnut Optimally combined with a really exclusive marble type: New Emperador.



VINTAGE 02

Colore composizione: Noce.

Materiali: Legno multistrato e gambe in legno massello.

Top lavabo: Piano in marmo New Emperador e lavabo sottopiano universale.



Color composition: Walnut.

Materials: Multilayer wood and solid wood legs.

Top: New Emperador marble top and standard wash-basin undertop.

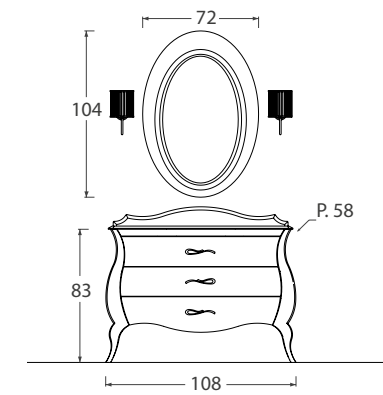



VINTAGE 03

Grande effetto anche in una delle finiture più tradizionali: il bianco lucido. In ottimale abbinamento con un marmo davvero esclusivo: il Nero Marquina.



It creates a great effect even with a more traditional finish: glossy white. Optimally combined with a truly exclusive marble type: Black Marquina.



VINTAGE 03

Colore composizione: Bianco lucido.
Materiali: Legno multistrato e gambe in legno massello.
Top lavabo: Piano in marmo Nero Marquina e lavabo sottopiano universale.



Color composition: Glossy white.
Materials: Multilayer wood and solid wood legs.
Top: Black Marquina marble top and standard wash-basin undertop.

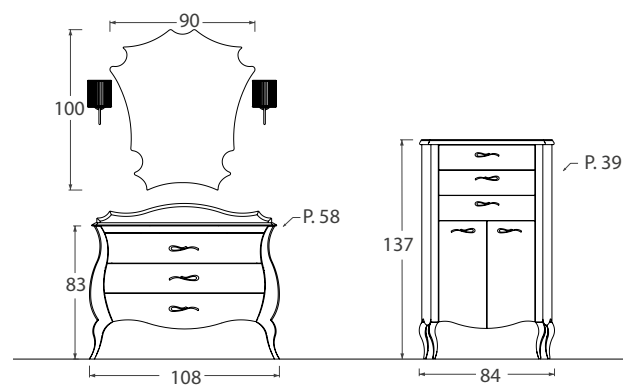



VINTAGE 04

Grande scelta di raffinatezza, soluzione di prestigio per chi ama colori non appariscenti ma soluzioni stilistiche e oggetti di grande valore.



Refined and prestigious choice for those who love sober colours, stylish solutions and objects of great value.

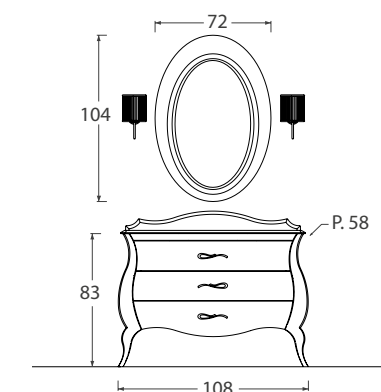

VINTAGE 04

Colore composizione: Grigio antracite lucido e cassetti in foglia argento.
Materiali: Legno multistrato e gambe in legno massello.
Top lavabo: Cristallo integrale extrachiaro colore grigio antracite.



Color composition: Glossy anthracite grey and silver leaf drawers.
Materials: Multilayer wood and solid wood legs.
Top: Integrated extra light anthracite grey glass.



VANITY. LINEE MORBIDE E SINUOSE

CLASSICO ED INTRAMONTABILE... LE LINEE MORBIDE E SINUOSE EVOCANO LA SUA TRADIZIONE ARTIGIANA. LA SUA FONDAMENTALE CARATTERISTICA STA NELLE COMPLESSE CURVATURE DELLA PARTE FRONTALE E DEI FIANCHI. DERIVATO DA UN CLASSICO COMÒ IN STILE VENEZIANO, IL VANITY È ATTUALIZZATO E OPPORTUNAMENTE STILIZZATO PER ESSERE IN VARIO MODO AMBIENTATO A CONTESTI ETEROGENEI: PRETTAMENTE CLASSICO, ELEGANTE O PIÙ GIOVANE E MODERNO. IL VANITY È DISPONIBILE IN DUE VERSIONI: CLASSICO MONOBLOCCO CON DUE CASSETTONI, O ELEGANTE E MINIMALE CONSOLLE CON UN SOLO CASSETTO.



CLASSIC AND TIMELESS...

Soft and sinuous lines evoke its craftsman tradition. Its key feature is the complex curvature of the front and sides. Derived from a classic Venetian-style commode, the vanity has been updated and appropriately styled to fit beautifully into various environments and a broad range of settings: purely classical, elegant, or younger and contemporary. The Vanity is available in two different versions: the classic one-piece with two drawers, or an elegant and minimalist cabinet with a single drawer.





VANITY 01

Colore composizione: Laccato bianco lucido.

Materiali: Realizzato quasi interamente in legno massello, alcune parti interne e i frontali curvati sono in legno multistrato.

Specchiera e illuminazione: Legno massello, lampade a muro in ottone cromato con paralume in stoffa bianco.

Top lavabo: Cristallo integrato "float spessore 15 mm", nero.



Color composition: Gloss white lacquer.

Materials: Made almost entirely of solid wood, several internal parts and curved fronts are made of plywood.

Mirror and Lighting: Solid wood, chromed brass wall lights with white fabric shades.

Top: Integrated black float glass top, 15 mm thick.

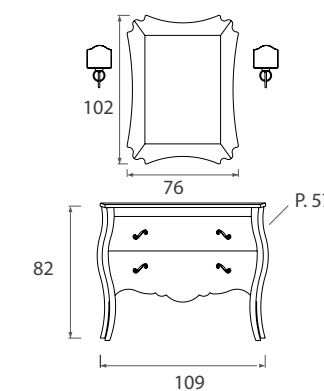



VANITY 02





VANITY 02

Colore composizione: Laccato nero lucido.

Materiali: Realizzato quasi interamente in legno massello, alcune parti interne e i frontali curvati sono in legno multistrato.

Specchiera e illuminazione: Legno massello, lampade a muro in ottone cromato con paralume in stoffa bianco.

Top lavabo: Marmo Bianco Stellar con lavabo sottopiano.



Color composition: Black gloss lacquer.

Materials: Made almost entirely of solid wood, several internal parts and curved fronts are made of plywood.

Mirror and Lighting: Solid wood, chromed brass wall lights with white fabric shades.

Top: White Stellar marble with under-mount basin.

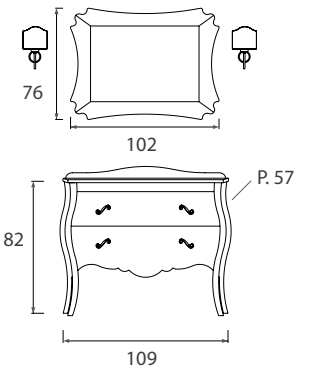



VANITY 03



VANITY 03

Colore composizione: Noce antico.
Materiali: Realizzato quasi interamente in legno massello, alcune parti interne e i frontali curvati sono in legno multistrato.
Specchiera e illuminazione: Legno massello, lampade in ottone cromato.
Top lavabo: Marmo Botticino ricomposto con lavabo sottopiano.



Color composition: Antique walnut.
Materials: Made almost entirely of solid wood, several internal parts and curved fronts are made of plywood.
Mirror and Lighting: Solid wood, lights of chromed brass.
Top: Botticino technical recomposed marble and under-mount basin.

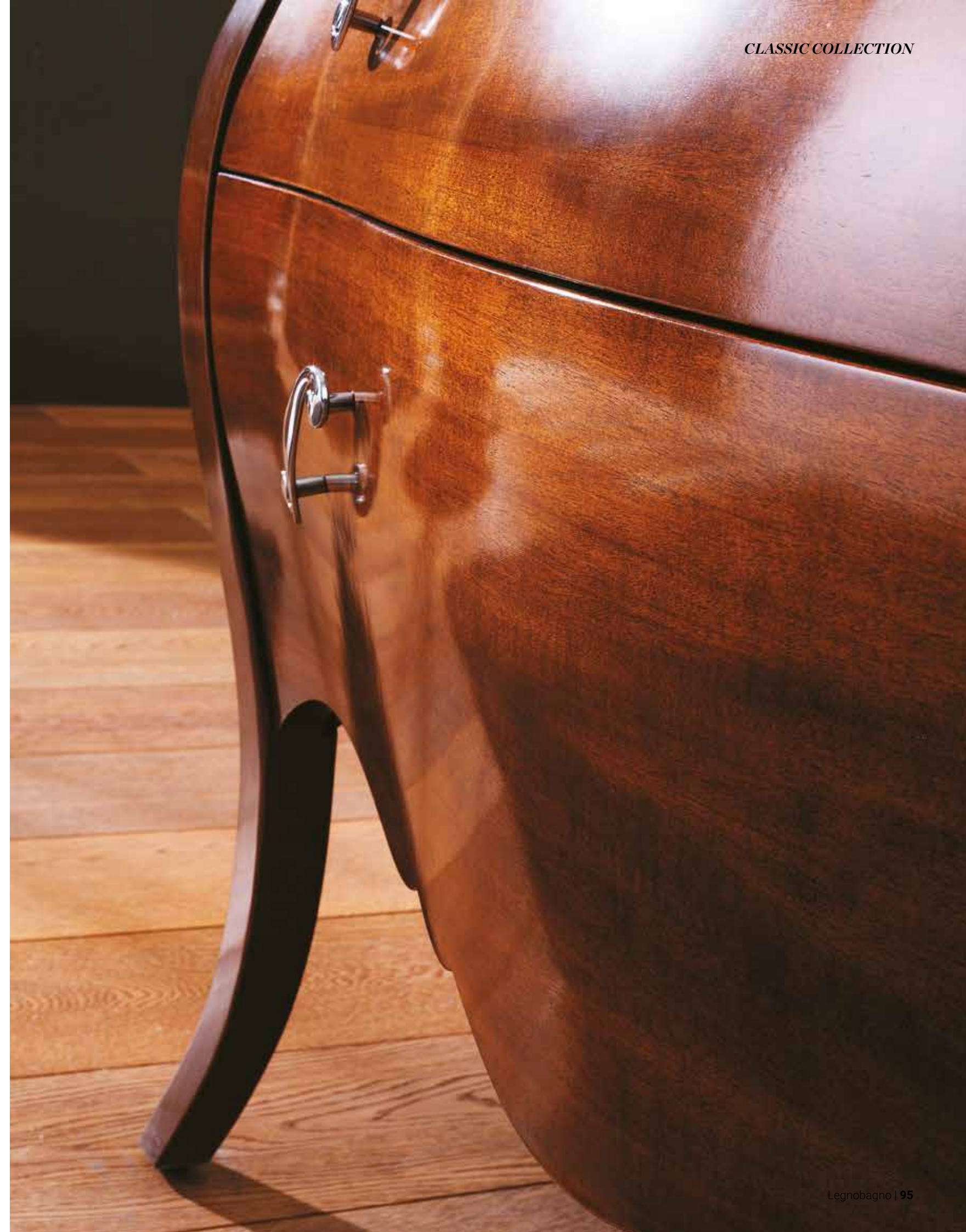
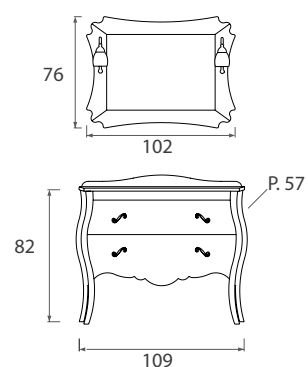

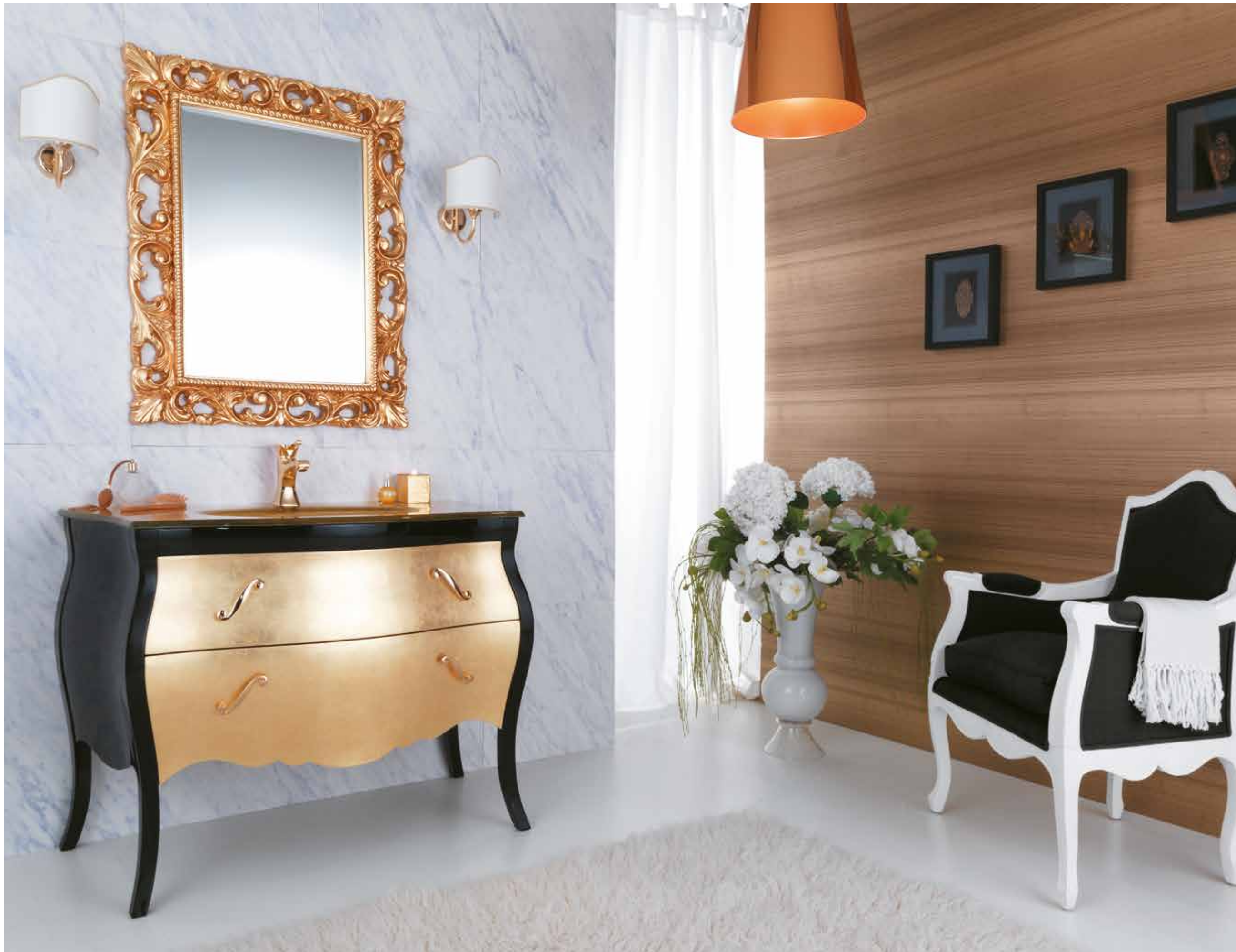

VANITY 05





VANITY 05

Colore composizione: Struttura nero lucido, cassettoni in foglia oro.
Materiali: Realizzato quasi interamente in legno massello, alcune parti interne e i frontali curvati sono in legno multistrato.
Specchiera e illuminazione: Cornice specchiera in materiale poliuretano, laccata oro e specchio bisellato, lampade a muro in ottone dorato.
Top lavabo: Cristallo integrato "extrachiario spessore 15 mm". Rivestito in foglia oro



Color composition: Gloss black structure, drawers with gold leaf finish.
Materials: Made almost entirely of solid wood, several internal parts and curved fronts are made of plywood.
Mirror and Lighting: Mirror frame of polyurethane material finished in gold lacquer and beveled mirror; gilded brass wall lights.
Top: Integrated extra-bright glass top, 15 mm thick, gold leaf finish.

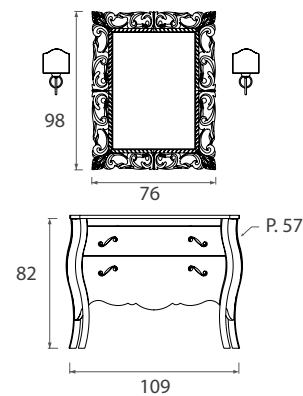



VANITY 06
❧



VANITY 06

Colore composizione: Laccato bianco lucido.

Materiali: Realizzato quasi interamente in legno massello, alcune parti interne e i frontali curvati sono in legno multistrato.

Specchiera e illuminazione: Cornice specchiera in materiale poliuretano laccata lucida e specchio bisellato, lampade a muro in ottone dorato.

Top lavabo: Cristallo integrato "extrachiario spessore 15 mm", rivestito in foglia oro.

Mobile di complemento: Sgabello contenitore, realizzato in legno massello e multistrato.



Color composition: White gloss lacquer.

Materials: Made almost entirely of solid wood, several internal parts and curved fronts are made of plywood.

Mirror and Lighting: Mirror frame of polyurethane material with high gloss finish and beveled mirror, gilded brass wall lights.

Top: Integrated extra-bright glass top, 15 mm thick, gold leaf finish.

Complementary furniture: Container stool, made of solid wood and plywood.

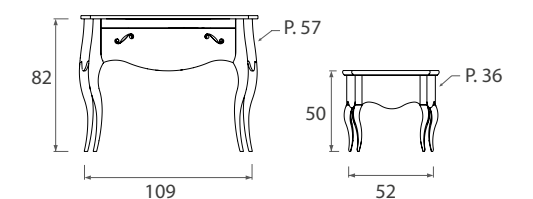
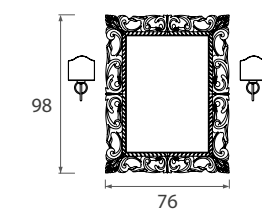



VANITY 08
❧



VANITY 08

Colore composizione: Noce antico.

Materiali: Realizzato quasi interamente in legno massello, alcune parti interne e i frontali curvati sono in legno multistrato.

Specchiera e illuminazione: Legno massello, lampade a muro in ottone cromato.

Top lavabo: Marmo tecnico botticino ricomposto e lavabo sottopiano.

Mobili di complemento: Settimino realizzato in legno massello e multistrato.



Color composition: Antique walnut.

Materials: Made almost entirely of solid wood, several internal parts and curved fronts are made of plywood.

Mirror and Lighting: Solid wood, chromed brass wall lights.

Top: Botticino technical recomposed marble and under-mount basin.

Complementary furniture: Small chest of drawers made of solid wood and plywood.

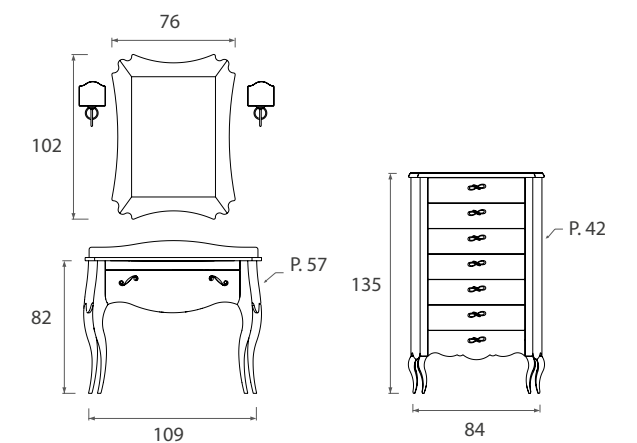

VANITY CAPITONNÉ. IL CLASSICO INTRAMONTABILE

QUESTO MOBILE, È IL GIÀ BEN NOTO VANITY. IL PRIMO PRODOTTO CHE HA DATO INIZIO AL CATALOGO STYLE. IN QUESTA NUOVA PROPOSTA È STATO RIVISITATO CON L'IMBOTTITURA CAPITONNÉ, L'EFFETTO È DI GRANDE RAFFINATEZZA. IL RIVESTIMENTO DONA AL MOBILE UNA FISIONOMIA DEL TUTTO NUOVA.



THE TIMELESS CLASSIC

This piece of furniture is the well-known Vanity. The first product that started the Style catalogue. Here, it has been revised with quilted padding creating a highly refined effect. The covering gives the piece a completely new appearance.



VANITY CAPITONNÉ

Intramontabile mobile Vanity... ora anche con imbottitura capitonné, giovane e classico al tempo stesso, si presta ad arredare i più svariati contesti.



Vanity is a timeless piece... now with quilted padding, young and classic at the same time, it lends itself to furnishing the most diverse environments.

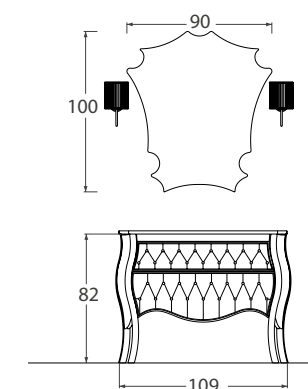

VANITY CAPITONNÉ

Colore composizione: Bianco lucido e cassetti con imbottitura capitonné in pelle bianca.
Materiali: Legno multistrato e gambe in legno massello.
Top lavabo: Lavabo integrale in cristallo bianco extrachiaro.
Apertura cassetti: Push-pull / Spingi apri.
I particolari: Lampade con Swarovski elements.



Color composition: Glossy white and drawers with white leather quilted padding.
Materials: Multilayer wood and solid wood legs.
Top: Integrated extra light white glass wash-basin.
Drawer opening: Push-pull / Push open.
Detail: Lamps with Swarovski elements.



VANITY DUETTO. L'ELEGANZA IN VERSIONE DOPPIA!

ANCORA SPAZIO AL VANITY. LA TANTO RICHIESTA VERSIONE CON DOPPIO LAVABO È FINALMENTE ARRIVATA. MERAVIGLIOSA SOLUZIONE PER CHI PUÒ PERMETTERSI QUESTO "LUI E LEI" DI GRANDE ELEGANZA. DISPONIBILE IN UNICA VERSIONE CON DUE ENORMI CASSETTONI, SONO POSSIBILI TUTTE LE FINITURE COMPRESA CHIARAMENTE L'IMBOTTITURA CAPITONNÉ.



ELEGANCE IN DOUBLE VERSION!

Another version of Vanity. The much-requested version with double wash-basin has finally arrived. A wonderful solution for those who can afford this elegant "His and Hers" version. Available only in one version with two huge dressers, all finishes are available including quilted padding.



VANITY DUETTO

Come restare indifferenti guardando questa foto? Soluzione d'arredo unica, davvero il mobile dei sogni. Ricchezza ed eleganza senza nessun risparmio!



How can you not react to this photo? A unique furniture solution, really the furniture of your dreams. Richness and elegance which spares nothing!





VANITY DUETTO 01

Colore composizione: Struttura rosa e cassetti con imbottitura capitonn  in pelle bianca.

Materiali: Legno multistrato e gambe in legno massello.

Top lavabo: Lavabo integrale in cristallo rosa extrachiaro.

Apertura cassetti: Push-pull / Spingi apri.

I particolari: Lampade con Swarovski elements.



Color composition: Pink frame and drawers with white leather quilted padding.

Materials: Multilayer wood and solid wood legs.

Top: Integrated extra light pink glass wash-basin.

Drawer opening: Push-pull / Push open.

Detail: Lamps with Swarovski elements.

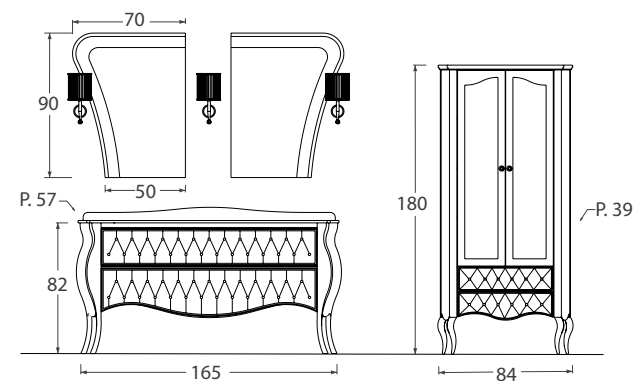



**VANITY
DUETTO 02**





VANITY DUETTO 02

Colore composizione: Noce.
Materiali: Legno multistrato e gambe in legno massello.
Top lavabo: Piano in marmo tecnico Botticino e lavabo sottopiano universale.



Color composition: Walnut.
Materials: Multilayer wood and solid wood legs.
Top: Botticino marble top and standard wash-basin undertop.

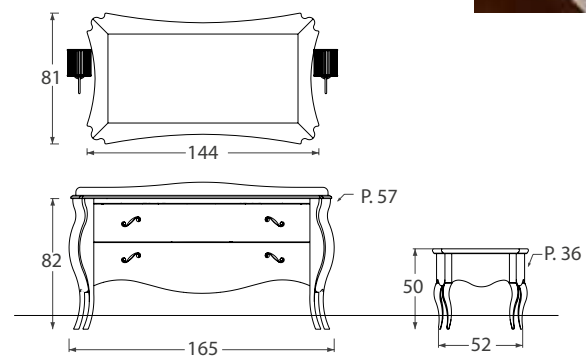

VANITY
DUETTO 03





VANITY DUETTO 03

Colore composizione: Bianco lucido.
Materiali: Legno multistrato e gambe in legno massello.
Top lavabo: Lavabo integrale in cristallo nero.



Color composition: Glossy white.
Materials: Multilayer wood and solid wood legs.
Top: Integrated black glass wash-basin.

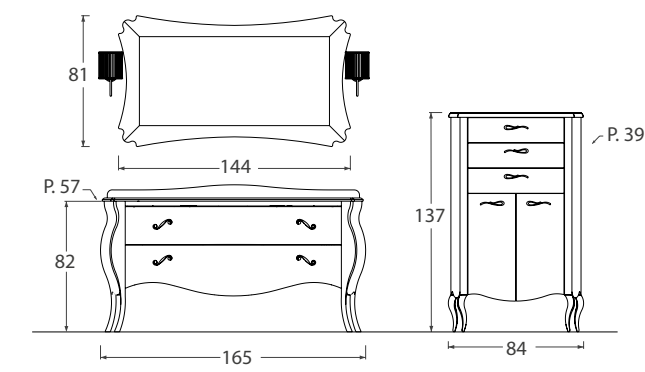

VANITY INTAGLIATO. CONNUBIO PERFETTO TRA ARTIGIANALITÀ E ARTE

QUESTA CONSOLLE È UN VERO ESEMPIO DI ESPRESSIONE ARTISTICA, DI ABILITÀ E DI SAPIENZA MANUALE. È REALIZZATA IN LEGNO MASSELLO ED È SCOLPITA NEL LEGNO CON TECNICHE ARTIGIANALI ED ARTISTICHE ORMAI FUORI DAL COMUNE. CI PROIETTIAMO IN ALTRI TEMPI, QUANDO I NOSTRI MAESTRI FORGIAVANO OGGETTI UNICI CON L'AUSILIO DI POCHI E SEMPLICI STRUMENTI, MA SOPRATTUTTO CON L'INCREDIBILE ABILITÀ DELLE LORO MANI. QUESTA ARTE NON SI È DEL TUTTO PERSA E RIESCE ANCORA A TRAMANDARSI CON GRANDE RARITÀ. L'INTAGLIO È UN LAVORO DURO, FATTO DI PRECISIONE CREATIVITÀ, FATICA E MOLTO TEMPO. DA NOTARE LA PREZIOSITÀ ANCHE NEI PARTICOLARI DEGLI ACCESSORI: LE SPLENDEDE MANIGLIE E LE LAMPADE CON BRACCETTI RIVESTITI IN FOGLIA ORO ED ARGENTO.



PERFECT COMBINATION OF ART AND CRAFTSMANSHIP This console table is a true example of artistic expression, skill and manual dexterity. It is made of solid wood, carved using traditional, artistic techniques, not commonly found today. We focus on the past, when our masters forged unique objects with the help of a few simple tools, but above all with incredible manual expertise. This art is not entirely lost and is still passed down from generation to generation, but it happens rarely. Carving is hard work and requires precision, creativity, effort and a lot of time. The precious details of the accessories are also noteworthy: the beautiful handles and lamps with arms covered with gold and silver leaf.





VANITY INTAGLIATO 01

Aspirare al massimo, avere l'accortezza di soffermarsi ad osservare ogni singolo, meraviglioso particolare. Nulla è lasciato al caso, dalla lavorazione della pietra alle preziose lampade, rivestite in foglia argento.



Aspiring to the maximum, being careful to stop and observe every single wonderful detail. Nothing is left to chance, from the craftsmanship of the stone to the precious lamps, covered in silver leaf.



VANITY INTAGLIATO 01

Colore composizione: Bianco antico.

Materiali: Legno multistrato e gambe in legno massello.

Top lavabo: Top in marmo tecnico "Rosso Asiago" e lavabo sottopiano universale.

I particolari: Lampade con braccetti rivestiti in foglia argento.



Color composition: Antique white

Materials: Multilayer wood and solid wood legs.

Top: "Rosso Asiago" marble top and standard wash-basin undertop.

Detail: "Rosso Asiago" marble top and standard wash-basin undertop.

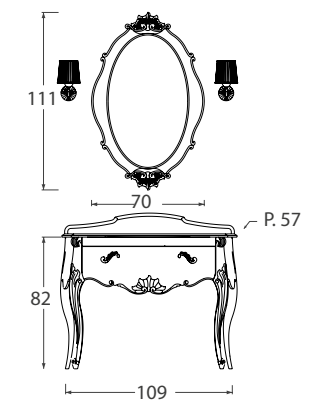

NARCISO UN CLASSICO ATTUALIZZATO

UN CLASSICO, SEMPLIFICATO ED ATTUALIZZATO, DEL MOBILE IN STILE VENEZIANO. DISPONIBILE IN DUE VERSIONI: CON DUE ANTE O IN ALTERNATIVA DUE ANTE E DUE CASSETTI. A SECONDA DEGLI ABBINAMENTI DI TOP E FINITURE, PUÒ ADATTARSI A CONTESTI ESTREMAMENTE CLASSICI ED ELEGANTI, COME ESSERE PIÙ MODERNO ED ATTUALE.



AN UPDATED CLASSIC

A classic, simplified and updated, of furniture in soft and venetian style. Available in two versions: either with two doors, or with two doors and two drawers. It adapts to extremely classical and elegant settings or to modern and contemporary settings depending on the combination of top and finish chosen.

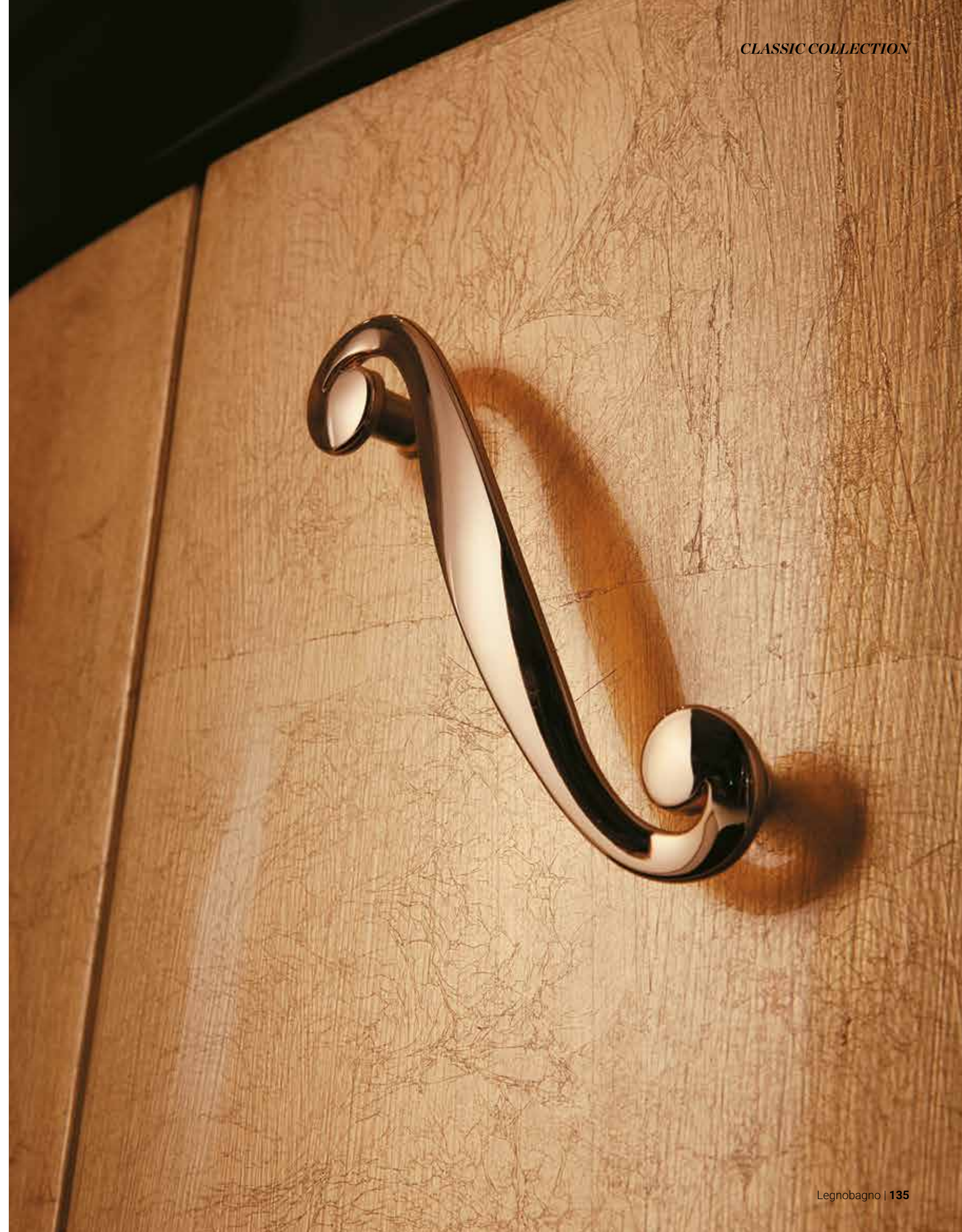



NARCISO 01





NARCISO 01

Colore composizione: Laccato bianco lucido.
Materiali: Struttura in legno massello, ante in legno multistrato.
Specchiera e illuminazione: Cornice specchiera in materiale poliuretanico laccata lucida e specchio bisellato, lampade a muro in ottone cromato.
Top lavabo: Cristallo integrato "float spessore 15 mm". Nero.
Mobile di complemento: "Comoncino" due ante e un cassetto, pensile con ante a vetrina realizzati in legno massello e multistrato.



Color composition: White gloss lacquer.
Materials: Structure in solid wood, door of plywood.
Mirror and Lighting: Mirror frame of polyurethane material with high gloss finish and beveled mirror, chromed brass wall lights.
Top: Integrated black float glass top, 15 mm thick.
Complementary furniture: Small commode with two doors and a drawer, hanging cabinet with glazed doors made of solid wood and plywood.

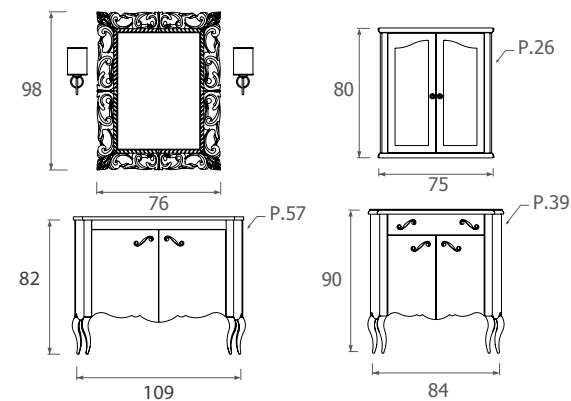

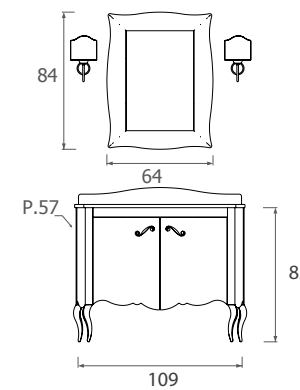

NARCISO 02

Colore composizione: Laccato rosso porpora lucido.

Materiali: Struttura in legno massello, ante in legno multistrato.

Specchiera e illuminazione: Specchiera in vetro fuso con scaglie di vetro, lampade a muro in ottone cromato.

Top lavabo: Marmo White Iceberg e lavabo sottopiano.



Color composition: Deep-red gloss lacquer.

Materials: Structure in solid wood, doors of plywood.

Mirror and Lighting: Mirror in fused glass with glass flakes, chromed brass wall lights.

Top: White Iceberg marble and under-mount.





NARCISO 04





NARCISO 04

Colore composizione: Laccato crema lucido.

Materiali: Struttura in legno massello, ante in legno multistrato.

Specchiera e illuminazione: Specchiera in legno massello, lampade a muro in ottone cromato.

Top lavabo: Marmo tecnico botticino ricomposto e lavabo sottopiano.

Mobile di complemento: Colonna alta con anta a vetrina e due cassetti, realizzata in legno massello e multistrato.



Color composition: Cream gloss lacquer.

Materials: Structure in solid wood, door of plywood.

Mirror and Lighting: Mirror in solid wood, chromed brass wall lights.

Top: Botticino technical recomposed marble and under-mount basin.

Complementary furniture: Tall column with glazed door and two drawers, made of solid wood and plywood.

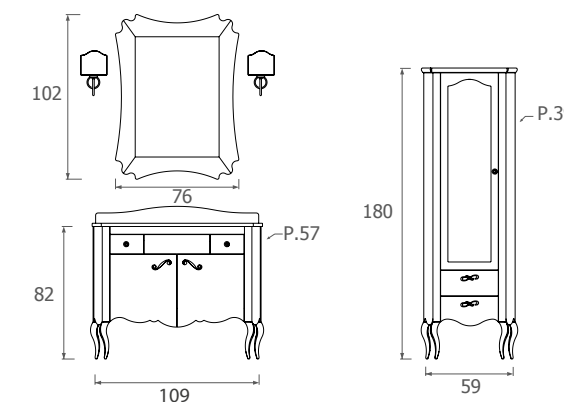

NARCISO 05



NARCISO 05

Colore composizione: Noce antico.

Materiali: Struttura in legno massello, ante in legno multistrato.

Specchiera e illuminazione: Legno massello, lampade in ottone cromato.

Top lavabo: Marmo tecnico botticino ricomposto e lavabo sottopiano.

Mobile di complemento: "Comoncino" due ante e un cassetto, pensile con ante a vetrina realizzati in legno massello e multistrato.



Color composition: *Antique walnut.*

Materials: *Structure in solid wood, door of plywood.*

Mirror and Lighting: *Solid wood, lights of chromed brass.*

Top: *Botticino technical recomposed marble and under-mount basin.*

Complementary furniture: *Small commode with two doors and a drawer, hanging cabinet with glazed doors made of solid wood and plywood.*

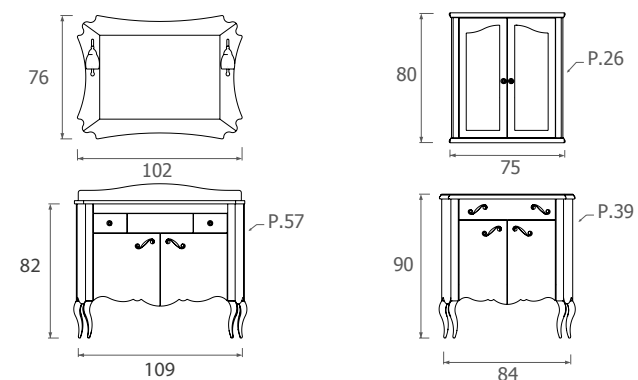

NARCISO DECORATO NEL SEGNO DELL'ARTE

ECCO IL NARCISO, UN MOBILE GIÀ CONOSCIUTO CHE FA PARTE DELLA PRECEDENTE COLLEZIONE STYLE. QUESTO SPENDIDO OGGETTO È UN VERO E PROPRIO QUADRO. I MOTIVI FLOREALI CHE SCONTORNANO FIANCHI, ANTE E CORNICE DELLO SPECCHIO, SONO REALIZZATI IN FOGLIA ORO E VENGONO RIFINITI A PENNELLO NEI CONTORNI. TUTTO È DIPINTO A MANO, ANCHE IL FONDO ANTICATO È REALIZZATO MANUALMENTE, SECONDO TECNICHE E TRADIZIONI D'ALTRI TEMPI. UN VERO OGGETTO AUTENTICO, DEDICATO AD AMATORI DEL GENERE.



IN THE NAME OF ART.

This is Narciso, a piece of furniture that has already been seen before and is part of the previous Style collection. This beautiful object is a real painting. The floral patterns that cut out the sides, doors and mirror frame are made of gold leaf and finished using a brush on the border. Everything is hand painted, even the antiqued background is created by hand, using ancient techniques and traditions. A true, authentic object, dedicated to lovers of this style.

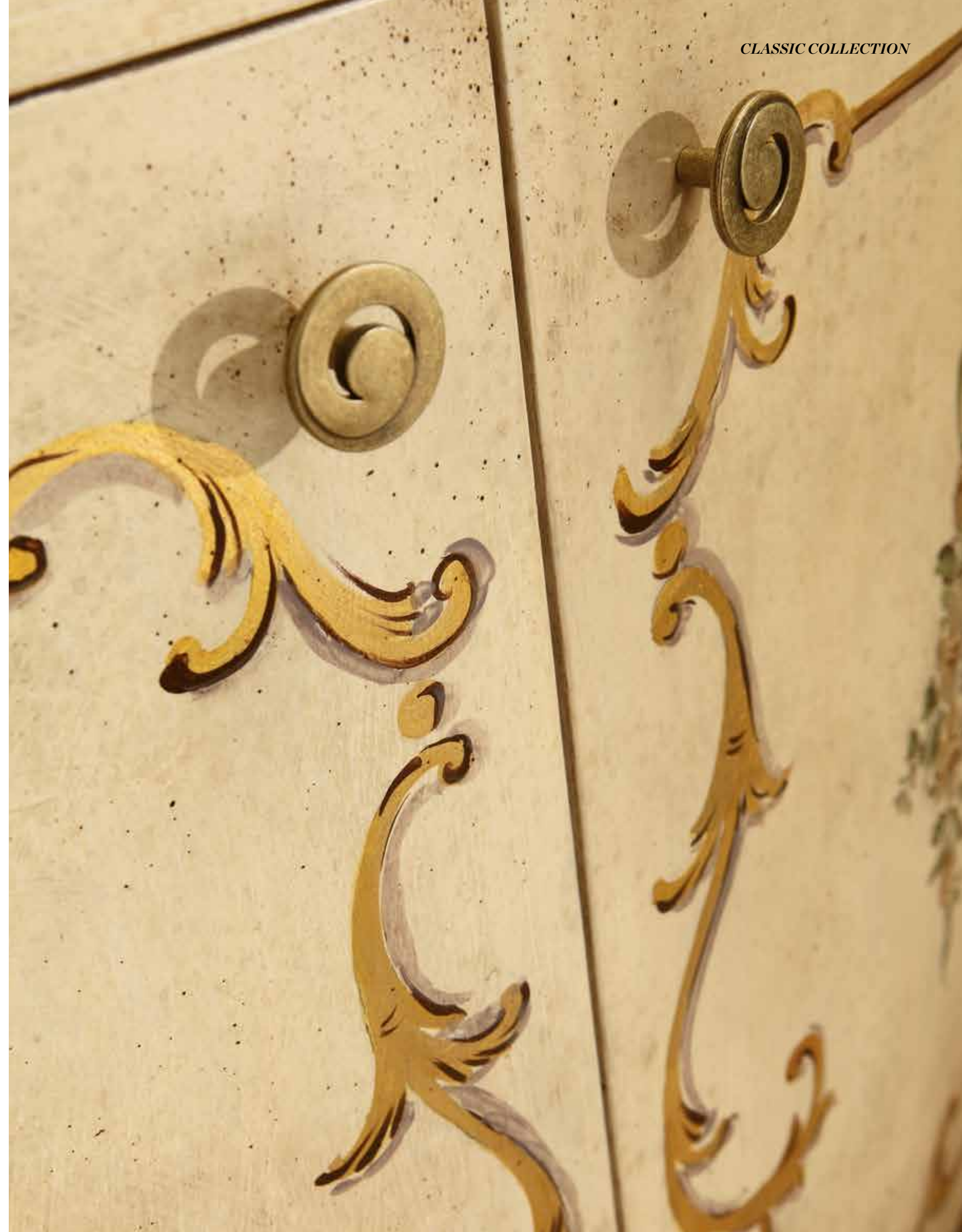



NARCISO DECORATO 01

Gli oggetti di pregio sono dedicati agli animi più sensibili, a chi sa dare un valore speciale, a volte sfuggente e inafferrabile, allo spazio che ci circonda.



Precious objects are dedicated to the more sensitive souls, who appreciate the special value they have, sometimes fleeting and elusive, to the space that surrounds us.



NARCISO DECORATO 01

Colore composizione: Panna invecchiata con decori floreali realizzati con pittura acrilica e foglia oro.

Materiali: Legno multistrato e gambe in legno massello.

Top lavabo: Top in marmo anticato biancone e lavabo sottopiano universale.

I particolari: Lampade con braccetti in ottone rivestiti in foglia oro.



Color composition: Antique cream with floral decorations created with acrylic paint and gold leaf.

Materials: Multilayer wood and solid wood legs.

Top: Antique white marble top and standard wash-basin undertop.

Detail: Lamps with brass arms covered with gold leaf.

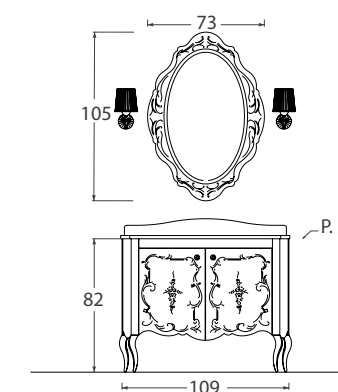

VOGUE DA CONSOLLE A MOBILE

DERIVATO DA UNA CONSOLLE CLASSICA COME CARATTERISTICO MOBILE DA INTERNO, IL VOGUE È FORSE FRA TUTTI, IL MOBILE PIÙ CARATTERISTICO E DI PARTICOLARE PREGIO. È DISPONIBILE IN DUE VERSIONI E MISURE: IL PIÙ GRANDE DA 120 CM CON QUATTRO CASSETTI E IL PIÙ PICCOLO DA 103 CM CON DUE CASSETTI. IL MAGGIORE, DI CARATTERE PIÙ CLASSICO E DI SPETTACOLARE ELEGANZA, BEN SI PRESTA ALLE FINITURE SPIGOLATE E AL RIVESTIMENTO IN FOGLIA. IL PIÙ PICCOLO, DI CARATTERE PIÙ MODERNO E "GIOVANILE", RISULTA DI PARTICOLARE IM PATTO NELLE FINITURE LACCATE, OLTRE AD AVERE LA POSSIBILITÀ DI ADATTARSI AL LAVABO INTEGRALE IN CERAMICA.



FROM CONSOLE TO FURNITURE.

Based on a classical console as a characteristic item of furniture, the Vogue is perhaps, among all of our furniture pieces, the most representative and of special desirability. It is available in two versions and sizes: the larger is 120 cm with four drawers and the smaller is 103 cm with two drawers. The larger is more classical and of spectacular elegance spectacular, and is well suited to rubbed through finishes as well as to a gold leaf finish. The smaller version has a younger and more modern feel and it is an impressive in a lacquer finish. It is also able to accommodate either an integrated or under-mounted basin.



VOGUE 01



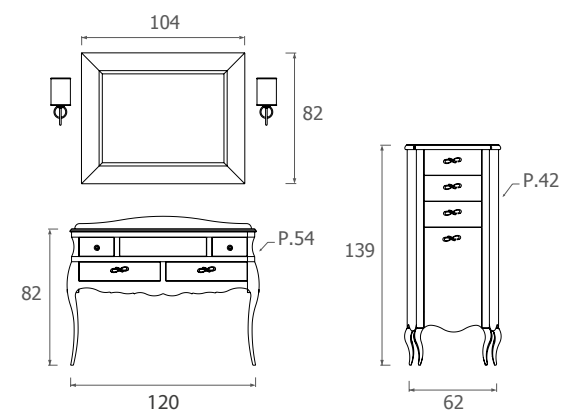

VOGUE 01

Colore composizione: Spigolato nero.

Materiali: Realizzato quasi interamente in legno massello, alcune parti interne sono in legno multistrato.

Specchiera e illuminazione: Legno massello, lampade a muro in ottone dorato.

Top lavabo: Marmo Gold Sahara e lavabo sottopiano.

Mobile di complemento: Colonna bassa con anta e 3 cassetti, realizzata in legno massello e multistrato.



Color composition: Black rubbed-through finish.

Materials: Made almost entirely of solid wood, several internal components of plywood.

Mirror and Lighting: Solid wood, gilded brass wall lights.

Top: Gold Sahara marble and under-mount basin.

Complementary furniture: Low column with door and three drawers, made of solid wood and plywood.

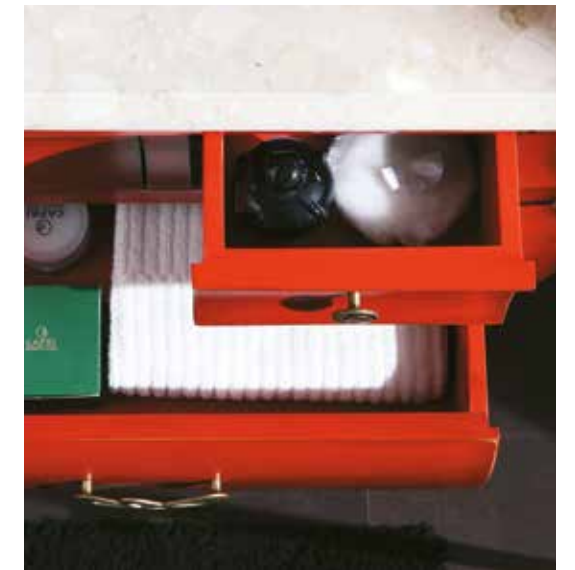

VOGUE 02

Colore composizione: Spigolato rosso.

Materiali: Realizzato quasi interamente in legno massello, alcune parti interne sono in legno multistrato.

Specchiera e illuminazione: Legno massello, lampade a muro in ottone dorato.

Top lavabo: Marmo tecnico botticino ricomposto e lavabo sottopiano.



Color composition: Red rubbed.

Materials: Made almost entirely of solid wood, several internal components of plywood.

Mirror and Lighting: Solid wood, gilded brass wall lights.

Top: Botticino technical recomposed marble and under-mount basin.

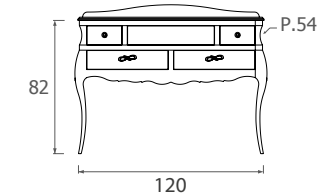
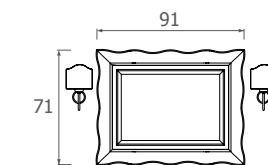



VOGUE 03





VOGUE 03

Colore composizione: Bianco spigolato.

Materiali: Struttura in legno massello, Ante e cassetti in legno multistrato.

Specchiera e illuminazione: Specchiera in legno massello, lampade a muro in ottone cromato.

Top lavabo: Marmo Gold Sahara e lavabo sottopiano.

Mobile di complemento: Colonna alta con anta a vetrina e due cassetti, realizzata in legno massello e multistrato.



Color composition: White rubbed.

Materials: Structure in solid wood, doors and drawers of plywood.

Mirror and Lighting: Mirror in solid wood, chromed brass wall lights.

Top: Gold Sahara marble and under-mount basin.

Complementary furniture: Tall column with glazed door and two drawers, made of solid wood and plywood.

Detail: Lamps with Swarovski elements.

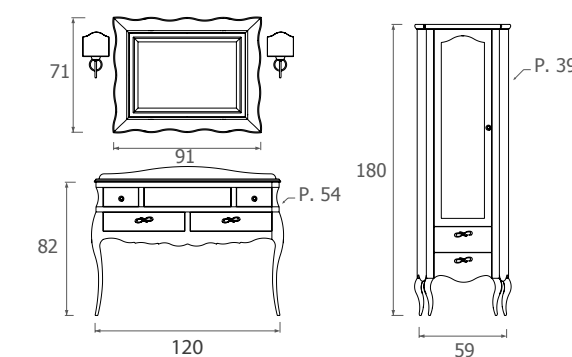



VOGUE 04

Colore composizione: Rivestito interamente in foglia oro.

Materiali: Realizzato quasi interamente in legno massello, alcune parti interne sono in legno multistrato.

Specchiera e illuminazione: Cornice specchiera in materiale poliuretano, laccata oro e specchio bisellato, lampade a muro in ottone dorato.

Top lavabo: Cristallo integrato "float spessore 15 mm", nero.



Color composition: Gold leaf finish overall.

Materials: Made almost entirely of solid wood, several internal components of plywood.

Mirror and Lighting: Cornice Mirror of polyurethane material finished in gold lacquer and beveled mirror, wall lights of gilt brass.

Top: Integrated black float glass top, 15 mm thick.

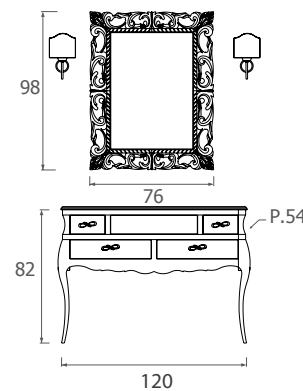



MINI-VOGUE 05





MINI-VOGUE 05

Colore composizione: Laccato bianco lucido.

Materiali: Realizzato quasi interamente in legno massello, alcune parti interne e frontali curvi sono in legno multistrato.

Specchiera e illuminazione: Specchiera in vetro fuso con scaglie di vetro, lampade a muro in ottone cromato.

Top lavabo: Lavabo integrale in ceramica.

Mobilità di complemento: Settimino realizzato in legno massello e multistrato.



Color composition: White gloss lacquer.

Materials: Made almost entirely of solid wood, several internal components and curved fronts are made of plywood.

Mirror and Lighting: Mirror in fused glass with glass, chromed brass wall lights.

Top: Integral ceramic basin.

Complementary furniture: Small chest of drawers made of solid wood and plywood.

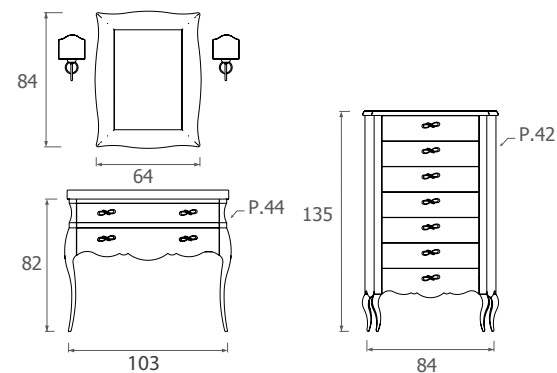



MINI-VOGUE 06

Colore composizione: Laccato Caffè Latte lucido.
Materiali: Realizzato quasi interamente in legno massello, alcune parti interne e frontali curvi sono in legno multistrato.
Specchiera e illuminazione: Legno massello, lampade a muro in ottone cromato.
Top lavabo: Lavabo integrale in ceramica.



Color composition: Gloss Coffee Milk lacquer.
Materials: Made almost entirely of solid wood, several internal components and curved fronts are made of plywood.
Mirror and Lighting: Solid wood, chromed brass wall lights.
Top: Integral ceramic basin.

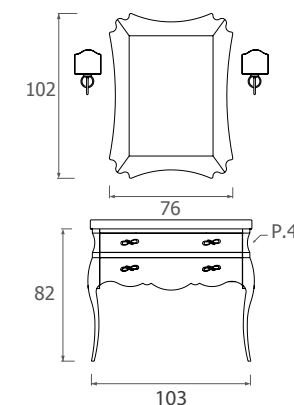

NOVECENTO FINITURE E INTARSI DI PREGIO

QUESTO PARTICOLARISSIMO MOBILE, DISPONIBILE IN UNICA VERSIONE CON 5 CASSETTI, SI CARATTERIZZA PER LE LINEE SINUOSE ED ARMONICHE. LE FINITURE ARTIGIANALI DI PREGIO COME L'INTARSIO E LA PARTICOLARE LAVORAZIONE DELLE GAMBE, NE FANNO UN OGGETTO UNICO E DI GRANDE PREGIO, EVOCANDO PER L'APPUNTO UN ARREDO DEI PRIMI ANNI DEL NOVECENTO. TECNICAMENTE È EQUIPAGGIATO DI MODERNE GUIDE CON CHIUSURA ASSISTITA E SI PUÒ OTTENERE IN MOLTEPLICI FINITURE: LACCATO LUCIDO E OPACO, ANTICATO, NOCE ANTICO O RIVESTITO IN FOGLIA.



FINISHES AND INLAYS OF VALUE.

Characterized by its sinuous and harmonious lines, this unique piece of furniture is available in only this version with five drawers.

The high-quality artisan finishes such as intarsia and the special carving of the legs make it a unique and extremely desirable piece that accurately evokes decor of the early twentieth century. Technically it is equipped with modern guides with assisted closure, and can be obtained in a wide range of finishes: gloss, matte, antique, antique walnut or gold/ silver leaf.

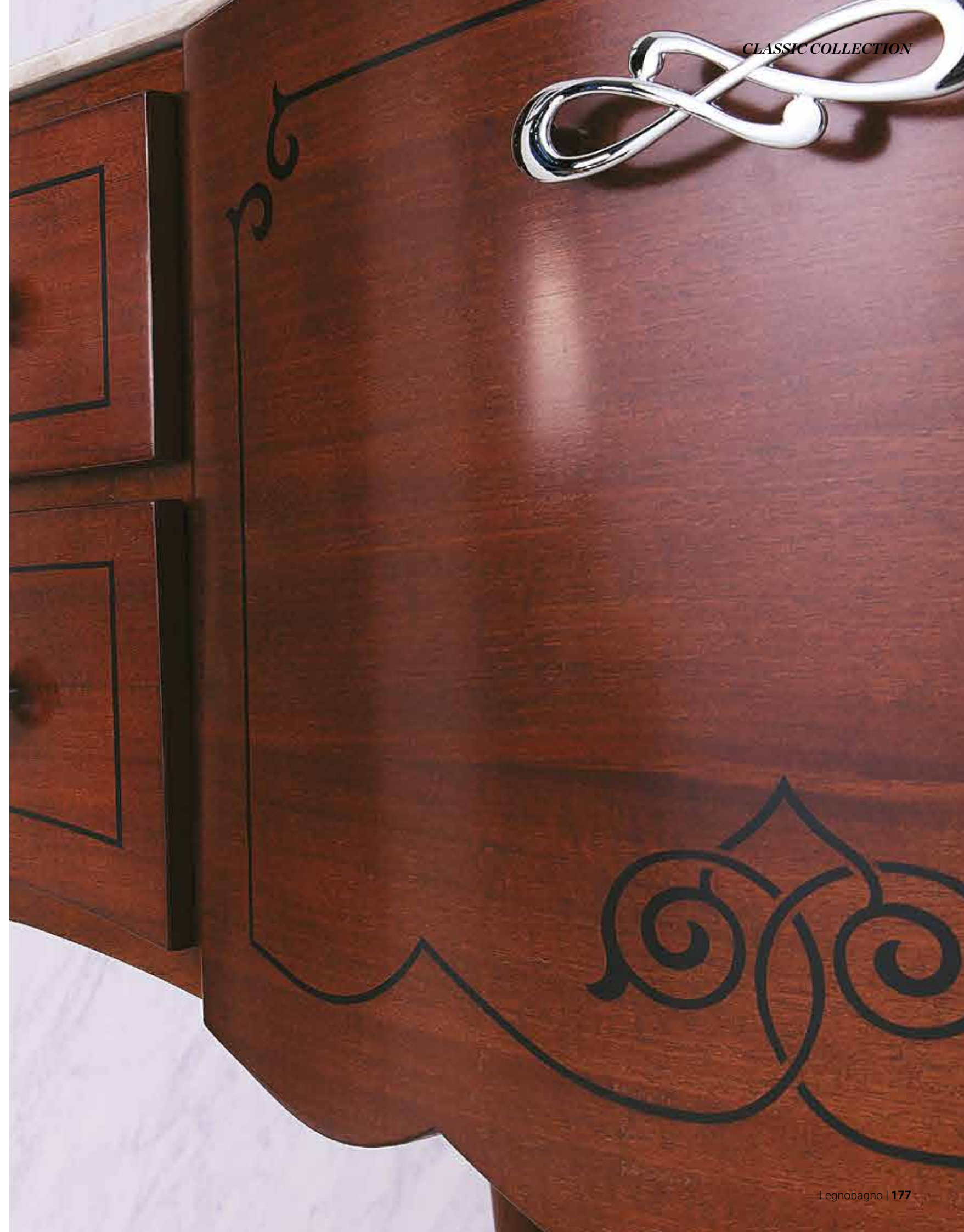



NOVECENTO 01





NOVECENTO 01

Colore composizione: Noce antico.

Materiali: Struttura in legno massello, cassetti in legno multistrato con intarsio ligneo.

Specchiera e illuminazione: Legno massello, lampade in ottone cromato.

Top lavabo: Marmo tecnico botticino ricomposto e lavabo sottopiano.

Mobile di complemento: Colonna con ante a vetrina e due cassetti + sgabello contenitore, realizzati in legno massello e multistrato.



Color composition: Antique walnut.
Materials: Structure in solid wood, drawers of plywood with intarsia inlay.

Mirror and Lighting: Solid wood, lamps of chromed bronze.

Top: Botticino technical recomposed marble and under-mount basin.

Complementary furniture: Column with glazed doors and two drawers and container stool, made of solid wood and plywood.

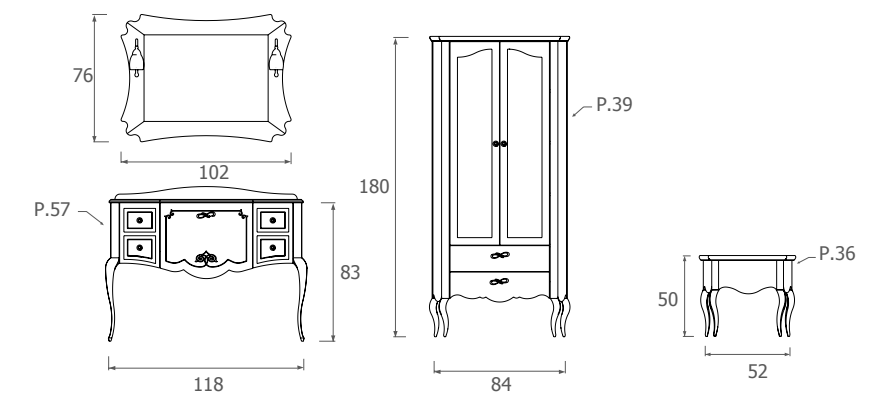



NOVECENTO 02





NOVECENTO 02

Colore composizione: Struttura laccato nero lucido, cassetti foglia argento.
Materiali: Struttura in legno massello, cassetti in legno multistrato rivestito con foglia argento.
Specchiera e illuminazione: Legno massello rivestito in foglia argento, lampade a muro in ottone cromato.
Top lavabo: Cristallo integrato "float spessore 15 mm", nero



Color composition: Structure black gloss lacquered, drawers with silver leaf finish.
Materials: Structure in solid wood, drawers of plywood with silver gilt finish.
Mirror and Lighting: Solid wood with silver-leaf finish, chromed brass wall lights.
Top: Integrated black float glass top, 15 mm thick.

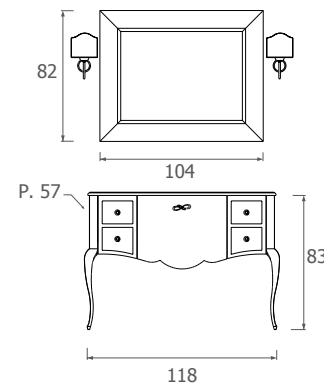



NOVECENTO 03





NOVECENTO 03

Colore composizione: Sabbia antico.

Materiali: Struttura in legno massello, cassetti in legno multistrato.

Specchiera e illuminazione: Legno massello, lampade a muro in ottone cromato.

Top lavabo: Marmo tecnico botticino ricomposto e lavabo sottopiano.

Mobili di complemento: Colonna bassa con anta e due cassetti, realizzata in legno massello e multistrato.



Color composition: Antique sand.

Materials: Structure in solid wood, drawers of plywood.

Mirror and Lighting: Solid wood, chromed brass wall lights.

Top: Botticino technical recomposed marble and under-mount basin.

Complementary furniture: Low column with door and two drawers made of solid wood and plywood.

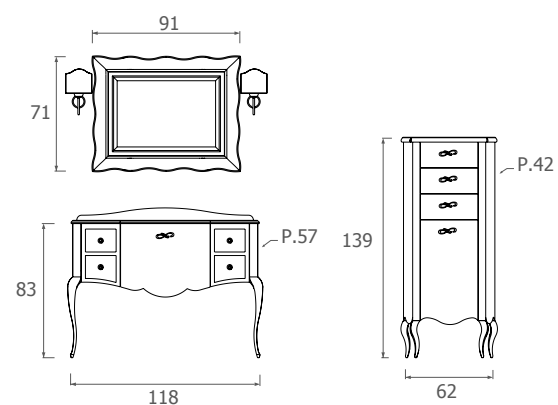



NOVECENTO 04





NOVECENTO 04

Colore composizione: Bianco lucido.

Materiali: Struttura in legno massello, cassetti in legno multistrato.

Specchiera e illuminazione: Particolare cornice a specchio curvata in fusione, lampade a muro in ottone cromato con paralume in stoffa nera.

Top lavabo: Cristallo integrato "float spessore 15 mm", nero.

Mobili di complemento: Sgabello contenitore, realizzato in legno massello e multistrato.



Color composition: White gloss.

Materials: Structure in solid wood, drawers of plywood.

Mirror and Lighting: Unusual mirror frame curved in the process of fusion, chromed brass wall lights with black fabric shades.

Top: Integrated black float glass top, 15 mm thick.

Complementary furniture: Container stool, made of solid wood and plywood.

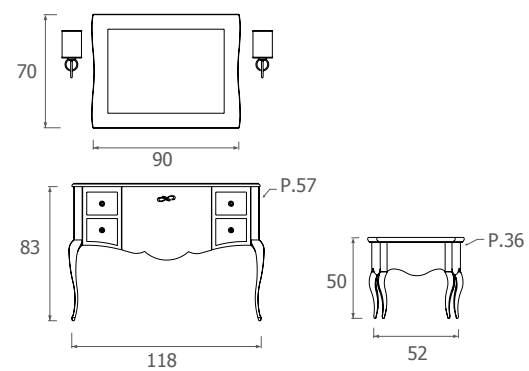

DECÒ CLASSIC & DECÒ FINITURE E INTARSI DI PREGIO

UNA SUPERBA COLLEZIONE DI MOBILI CON UNO STILE CLASSICO ASSOLUTAMENTE PERSONALE, PENSATO IN CHIAVE MODERNA, CON TUTTI GLI ACCORGIMENTI TECNOLOGICI E LE FINITURE PIÙ CURATE. LE COMPOSIZIONI SONO PROPOSTE IN MERAVIGLIOSE FINITURE LACCATE LUCIDE, PREZIOSI RIVESTIMENTI IN FOGLIA ORO O ARGENTO E FINITURE IN LEGNO DI ROVERE: NOCE E DECAPÈ. LE PRIME 10 COMPOSIZIONI SONO NOMINATE "DECÒ CLASSIC" E SI CARATTERIZZANO PER UNO STILE PIÙ CLASSICO ED ELABORATO. LE ALTRE 4 COMPOSIZIONI SONO NOMINATE SEMPLICEMENTE "DECÒ" E SONO UNA VERSIONE PIÙ MINIMALE E MODERNA DEL NOSTRO MODO DI PENSARE LO STILE "DECÒ".



A SUPERB COLLECTION OF FURNITURE WITH A CLASSIC,

and absolutely personal, style, conceived in a modern tone, with the most technological features and most careful finishes. The combinations are presented in marvelous gloss lacquered finishes, precious gold or silver leaf, and in wood including oak, walnut and "distressed". The first ten compositions are called "Classic Deco" and they feature a more classical and ornate style. The other four compositions are simply called "Deco" and they represent a more minimalist and modern interpretation of "Deco" style.





DECÒ D01

Colore composizione: Rosso porpora lucido.

Materiali: I frontali e le fiancate sono realizzati in multistrato curvato, piedini in massello e strutture interne in pannello idrorepellente, cassetti con sponde metalliche e chiusura rallentata.

Top lavabo: Consolle in ceramica integrale Decò classic cm 110.



Color composition: Porphyry red gloss.

Materials: Cabinet fronts and sides are of curved plywood, with solid wood feet, and internal structure is of water-repellant panels, drawers with stream lined "blumotion" series edges.

Top: Decò classic 110 cm. console ceramic basin.

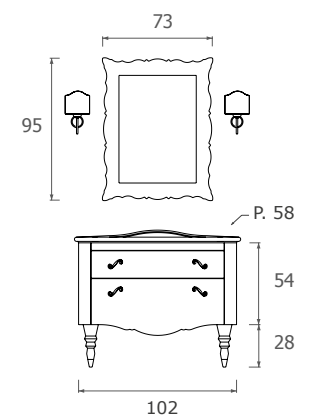



DECÒ D02





DECÒ D02

Colore composizione: Bianco lucido.

Materiali: I frontali e le fiancate sono realizzati in multistrato curvato, piedini in massello e strutture interne in pannello idrorepellente, cassetti con sponde metalliche e chiusura rallentata.

Top lavabo: Top in cristallo integrato float 15 mm nero.



Color composition: Gloss white.

Materials: Cabinet fronts and sides are of curved plywood, with solid wood feet, and internal structure is of water-repellant panels, drawers with streamlined "blumotion" series edges.

Top: Integrated black float glass basin, 15 mm.

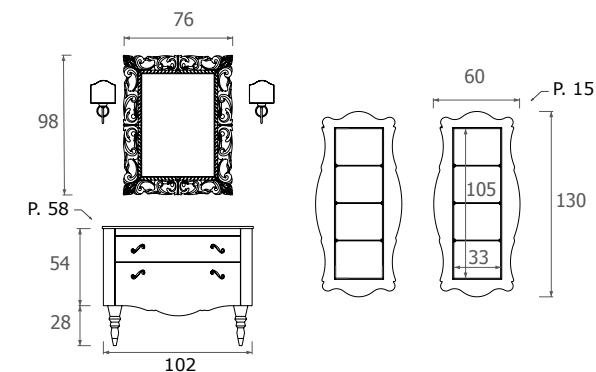

DECÒ D03

Colore composizione: Rovere moro decapè argento.

Materiali: I frontali e le fiancate sono realizzati in multistrato curvato impiallacciato rovere, piedini e specchiera in massello e strutture interne in pannello idrorepellente, cassetti con sponde metalliche e chiusura rallentata.

Top lavabo: Top in cristallo integrato extrachiaro 15 mm rivestito in foglia argento.



Color composition: Dark oak distressed with silver.

Materials: Cabinet fronts and sides are of oak-veneered curved plywood, with solid wood feet and mirror frame, internal structure is of water-repellant panels, drawers with streamlined "blumotion" series edges.

Top: Integrated extra light glass top, finished with silver leaf, 15 mm.

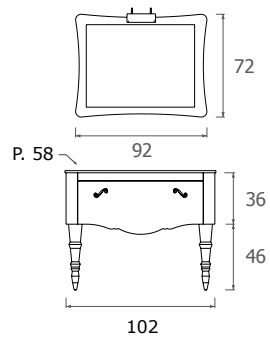



DECÒ D04
S



Particolare della colonna pensile nella sua versione con anta a specchio

Detail of the hanging cabinet version with mirrored door



DECÒ D04

Colore composizione: Rovere rosso porpora.

Materiali: I frontali e le fiancate sono realizzati in multistrato curvato impiallacciato rovere, piedini e specchiera in massello e strutture interne in pannello idrorepellente, cassetti con sponde metalliche e chiusura rallentata.

Top lavabo: Top in marmo bianco cristallino con lavabo sottopiano universale.



Color composition: Porphyry red oak.

Materials: Cabinet fronts and sides are of oak-veneered curved plywood, with solid wood feet and mirror frame, internal structure is of water-repellant panels, drawers with streamlined "blumotion" series edges.

Top: Crystal white marble top with universal undercounter basin.

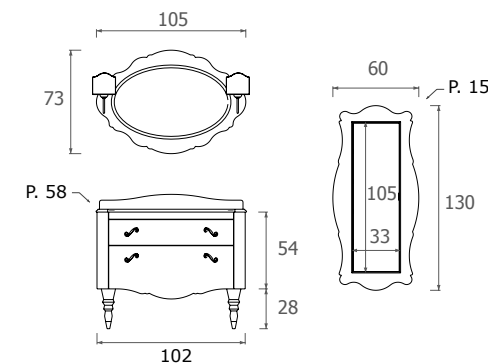



DECÒ D05
S



DECÒ D05

Colore composizione: Nero lucido.

Materiali: I frontali e le fiancate sono realizzati in multistrato curvato, piedini in massello e strutture interne in pannello idrorepellente, cassetti con sponde metalliche e chiusura rallentata.

Top lavabo: Top in cristallo integrato extrachiaro 15 mm rivestito in foglia oro.



Color composition: Gloss Black.

Materials: Cabinet fronts and sides are of curved plywood, with solid wood feet, and internal structure is of water-repellant panels, drawers with streamlined "blumotion" series edges.

Top: Integrated extra light glass top finished with gold leaf, 15 mm.

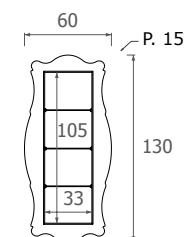
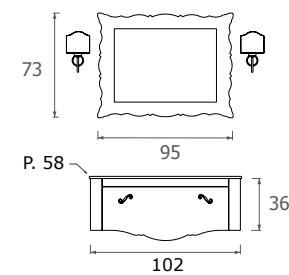



DECÒ D06
S



DECÒ D06

Colore composizione: Fucsia perlato lucido.

Materiali: I frontali e le fiancate sono realizzati in multistrato curvato, piedini in massello e strutture interne in pannello idrorepellente, cassetti con sponde metalliche e chiusura rallentata.

Top lavabo: Consolle in ceramica integrale Decò classic cm 90.



Color composition: Pearly pink gloss.

Materials: Cabinet fronts and sides are of curved plywood, with solid wood feet, and internal structure is of water-repellant panels, drawers with streamlined "blumotion" series edges.

Top: Integral counter incorporating Decò classic 90 cm ceramic basin.

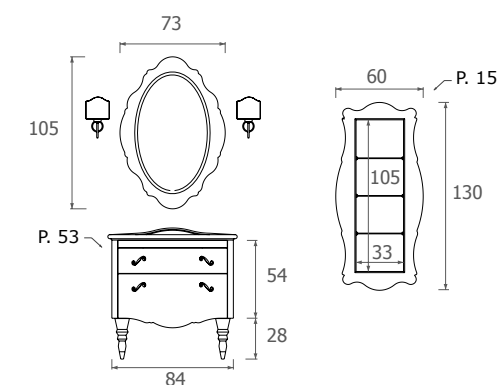

DECÒ D07
S



DECÒ D07

Colore composizione: Foglia argento e nero lucido.

Materiali: I frontali e le fiancate sono realizzati in multistrato curvato, piedini in massello e strutture interne in pannello idrorepellente, cassetti con sponde metalliche e chiusura rallentata.

Top lavabo: Top in cristallo integrato float 15 mm nero.



Color composition: Silver leaf and gloss black.

Materials: Cabinet fronts and sides are of curved plywood, with solid wood feet, and internal structure is of water-repellant panels, drawers with streamlined "blumotion" series edges.

Top: Integrated black float glass, 15 mm.

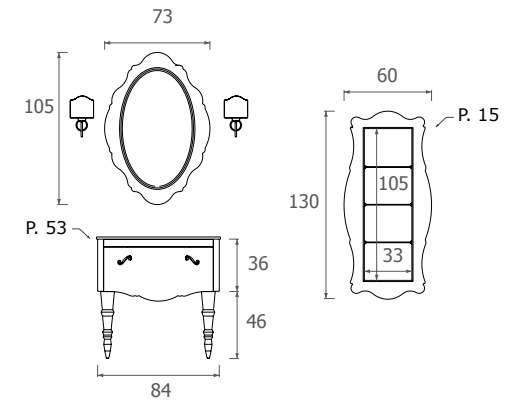



DECÒ D08

Colore composizione: Decapè bianco oro.
Materiali: I frontali e le fiancate sono realizzati in multistrato curvato impiallacciato rovere, piedini e specchiera in massello e strutture interne in pannello idrorepellente, cassetti con sponde metalliche e chiusura rallentata.
Top lavabo: Top in marmo travertino con lavabo sottopiano circolare.



Color composition: Decapè white gold.
Materials: Cabinet fronts and sides are of oak-veneered curved plywood, with solid wood feet and mirror frame, internal structure is of water-repellant panels, drawers with streamlined "blumotion" series edges.
Top: Travertine marble with circular undercounter basin.

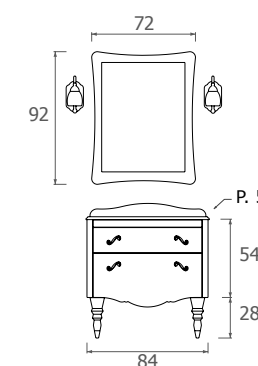



DECÒ D09

Colore composizione: Grigio antracite lucido.

Materiali: I frontali e le fiancate sono realizzati in multistrato curvato, piedini in massello e strutture interne in pannello idrorepellente, cassetti con sponde metalliche e chiusura rallentata.

Top lavabo: Top in cristallo integrato extrachiaro 15 mm violet.



Color composition: Anthracite grey gloss.

Materials: Cabinet fronts and sides are of curved plywood, with solid wood feet, and internal structure is of water-repellant panels, drawers with streamlined "blumotion" series edges.

Top: Integrated extra light violet glass, 15 mm.

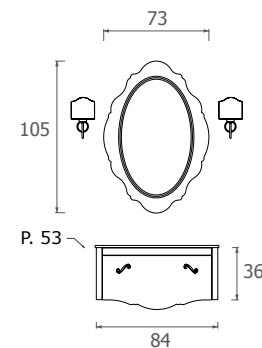



DECÒ D10

Colore composizione: Noce.

Materiali: I frontali e le fiancate sono realizzati in multistrato curvato impiallacciato rovere, piedini e specchiera in massello e strutture interne in pannello idrorepellente, cassetti con sponde metalliche e chiusura rallentata.

Top lavabo: Consolle in ceramica integrale Decò classic cm 90.



Color composition: Walnut.

Materials: Cabinet fronts and sides are of oak-veneered curved plywood, with solid wood feet and mirror frame, internal structure is of water-repellant panels, drawers with streamlined "blumotion" series edges.

Top: Integral counter incorporating Decò classic 90 cm ceramic basin.

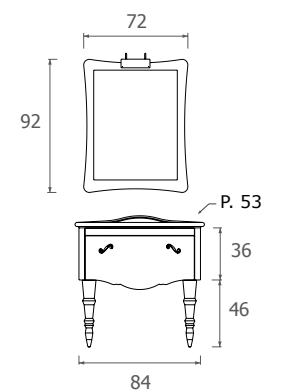



DECÒ D11
S



DECÒ D11

Colore composizione: Nero lucido e foglia argento.
Materiali: Pannello idrorepellente W100 cat. "A", cassetti con sponde metalliche e chiusura rallentata.
Top lavabo: Top in cristallo integrato float 15 mm nero.

Color composition: Black gloss and silver leaf.
Materials: Category A W100 water-repellant panels, drawers with streamlined "blumotion" series edges.
Top: Integrated black float glass, 15 mm.

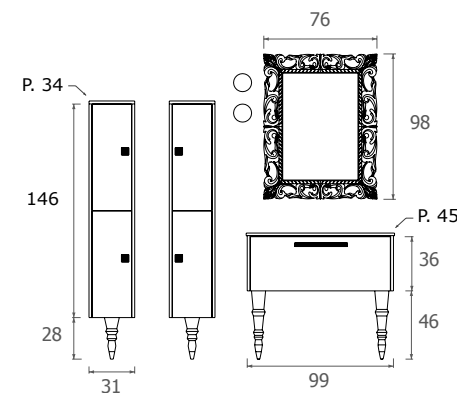

DECÒ D12
S





DECÒ D12

Colore composizione: Bianco lucido.
Materiali: Pannello idrorepellente W100 cat. "A", cassetti con sponde metalliche e chiusura rallentata.
Top lavabo: Consolle Decò in ceramica cm 100.



Color composition: Gloss white.
Materials: Category A W100 water-repellant panels, drawers with streamlined "blumotion" series edges.
Top: Console counter with integrated ceramic Decò basin, 100 cm.

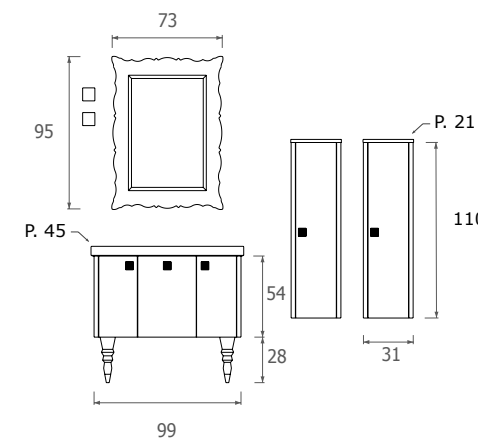



DECÒ D15

Colore composizione: Bianco lucido.

Materiali: Pannello idrorepellente W100 cat. "A", cassetti con sponde metalliche e chiusura rallentata.

Top lavabo: Cristallo extrachiaro 15 mm violet con lavabo ad appoggio softly.



Color composition: Gloss white.

Materials: Category A W100 water-repellant panels, drawers with streamlined "blumotion" series edges.

Top: Violet extra light glass, 15 mm, with "Softly" countertop basin.

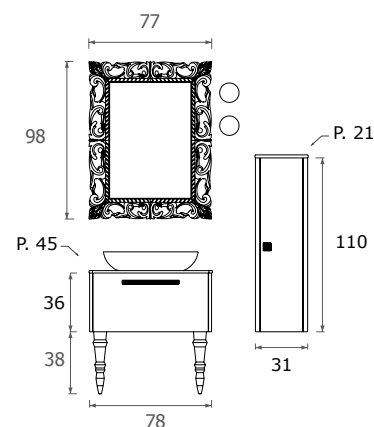



DECÒ D16
S



DECÒ D16

Colore composizione:

Nero lucido e foglia oro.

Materiali: Pannello idrorepellente W100 cat. "A", cassetti con sponde metalliche e chiusura rallentata.

Top lavabo: Cristallo integrato extrachiaro rivestito in foglia oro.



Color composition:
Gloss black and gold leaf.

Materials: Category A W100 water-repellant panels, drawers with streamlined "blumotion" series edges.

Top: Integrated extra light glass backed with gold leaf.

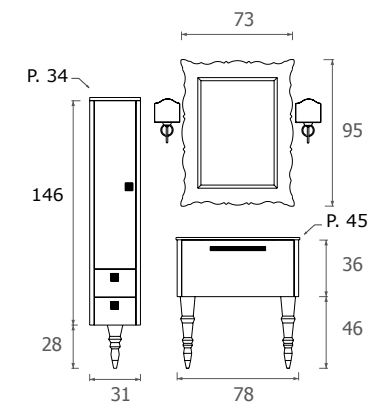

Classic

COLLECTION

CATALOGO CLASSIC COLLECTION
COMPONIBILI E MONOBLOCCHI

DESIGN

Legnobagno

ART DIRECTOR & RENDERING

Samuele Sciacovelli

PROGETTO GRAFICO

Studio21 srl

STAMPA

Arti Grafiche Celori
Stampato in Italia
Dicembre 2022

Legnobagno si riserva il diritto di apportare eventuali modifiche ai prodotti senza obbligo di preavviso o di sostituzione delle caratteristiche presenti a catalogo. La riproduzione fotografica dei colori e delle tonalità cromatiche può essere non perfettamente fedele alla realtà.

Legnobagno reserves the right to carry out modifications of the catalog products without prior notice. The photographic reproduction of colors and color shades may not be perfectly true to reality.

LEGNOBAGNO®
IL BAGNO CHE ARREDA

STABILIMENTO PRODUTTIVO

Via Alfredo Fieramonti (Zona Industriale)
04012 Cisterna di Latina (LT)
Tel: 06.9680943 - Fax: 06.9680948
E-mail: info@legnobagno.it

www.legnobagno.it

LEGNOBAGNO[®]
IL BAGNO CHE ARREDA

www.legnobagno.it